



*Caliber™ Pro  
Kamado*  
CHARCOAL GRILL & SMOKER  
KAMADO  STYLE  
MADE IN AMERICA

EXPECT  
GREAT  
HEAT™



**CALIBER**<sup>®</sup>  
APPLIANCES

# SEARING PERFECTION

With the searing power of mesquite and  
oak lump charcoal



[CALIBERAPPLIANCES.COM](http://CALIBERAPPLIANCES.COM)

# GIFTED GRILL

It's hard to beat the flavor of a perfectly seared steak over lump oak or mesquite.

The Caliber Pro Kamado Charcoal Grill takes grilling up a notch with its patent-pending flue-way system which assures better moisture retention in your grilled goods.

We know you'll have no complaints about your steaks and burgers being too juicy and flavorful.

“YOUR FAVORITE  
GRILLED RIB EYE  
JUST GOT BETTER.”







# ITALIAN WOOD OVEN

With our Pizza Stone accessory kit, the Caliber Pro Kamado converts to an Italian wood oven, giving you the best natural convection tool in the kitchen.



[CALIBERAPPLIANCES.COM](http://CALIBERAPPLIANCES.COM)

# PERFECT PIZZA

The efficient and unique dual layered insulated oven design of the Caliber Pro Kamado keeps heat and moisture in and wastes not . . .

Natural convection with added radiant reflection produces better airflow and browning than competitive top vented grills.



“HOMEMADE HAND  
TOSSED PIZZA PIE  
TAKES THE CAKE



BAKE



# INTEGRATED SYSTEM

Our patent-pending integrated rotisserie system makes this the most versatile grill in its class.



[CALIBERAPPLIANCES.COM](http://CALIBERAPPLIANCES.COM)



# ROCKIN' ROTISSERIE

Garlic and rosemary infused basting for an hour. Hands-free roasting while you prepare your side dishes for the poultry feast.

The industry exclusive, patent-pending integrated rotisserie option on the Caliber Pro Kamado turns chicken into the family favorite in just over an hour.

Crusted to perfection and rockin' with juicy goodness. Collect cooking juices for basting & sauce creation while keeping your grill clean and flare-up free.



“REALLY, REALLY, JUICY AND  
TENDER WHOLE CHICKEN  
IN AN HOUR

ROTISSERIE



# THERMAL COMPARISON

THERMAL COMPARISON IMAGES ILLUSTRATE CALIBER PRO KAMADO'S BETTER DESIGN AND HEATING EFFICIENCY VERSUS OTHER SMOKERS.



**CALIBER PRO KAMADO**

Much like an insulated stainless steel coffee cup that can be held in your hand despite the high internal temperatures, the Caliber Pro Kamado grill will hold heat inside and keep the outside cooler. In comparison, a ceramic mug which is filled with a hot liquid will need a handle since it conducts heat on the outside and is hot to the touch. Caliber has a triple layer of protection for efficiency and safety.

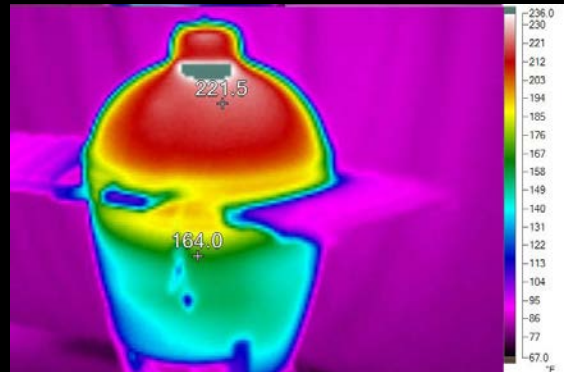

**OTHER CERAMIC SMOKERS**



## LESS CHARCOAL

Uses 40% less lump charcoal than ceramic grills.

FOR MORE TIPS AND GUIDES VISIT OUR WEBSITE: [CALIBERAPPLIANCES.COM](http://CALIBERAPPLIANCES.COM)



# SUPERB SMOKING

Is your smoker working for you or do you feel like you have to keep tending the fire every few hours?

With the Caliber Pro Kamado Grill & Smoker, you can relax and smoke with confidence.

Set the heat for Low and Slow at 225°F for 4, 5, or 6 hours and let our smoker do the work. Brisket fans can run the smoker on a single stock of fuel starting at 225°F and see the temperature at 205°F—12 hours later!



SIX (YES, SIX) RACKS OF  
ST. LOUIS STYLE RIBS DONE  
TO PERFECTION.

MY FAMOUS 12-HOUR  
GARLIC PULLED PORK  
ON ONE RUN OF FUEL!

LOW-N-SLOW SMOKER



# THE CALIBER ADVANTAGE

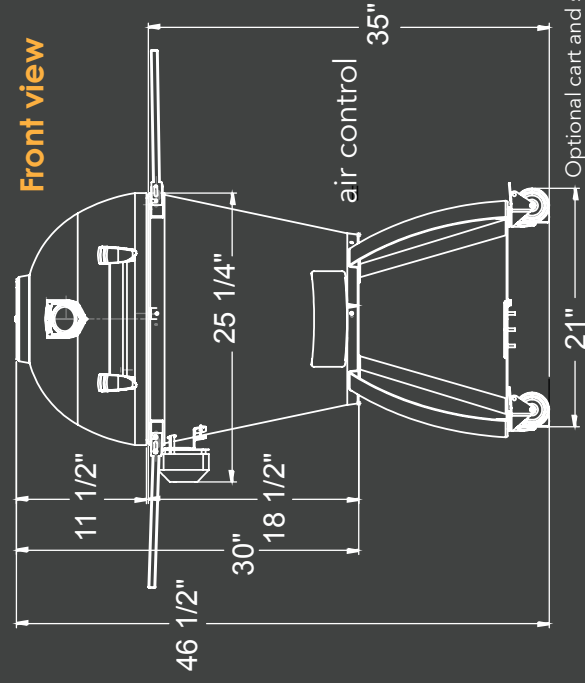
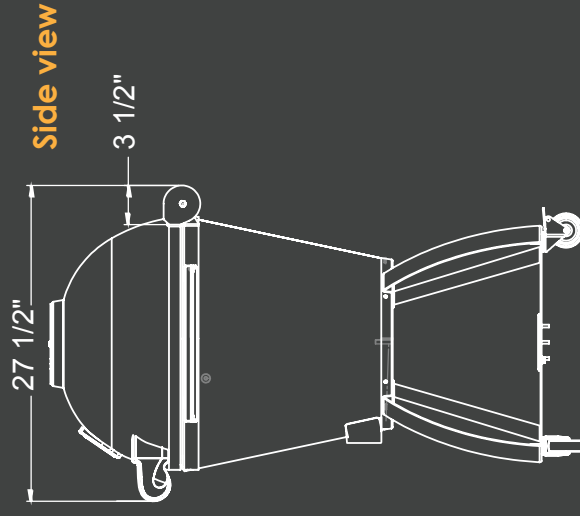
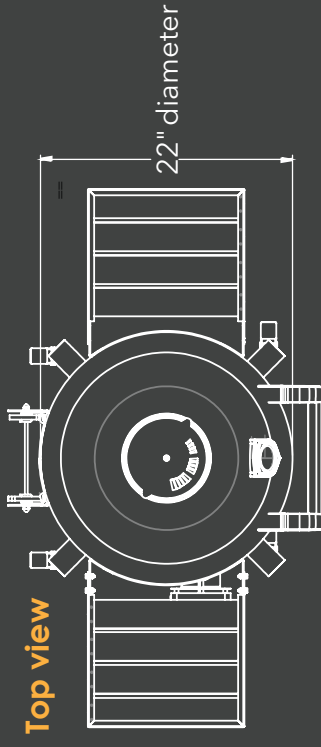

# CALIBER VS. CERAMIC

## FEATURES

### Construction Material

Two Layers of 304 Stainless Steel that encapsulates ultra-efficient thermal insulation (similar to self-clean ovens)

### Product Weight

75 lbs. (tailgate-able)

### Rotisserie

Industry exclusive, patent-pending integral rotisserie system with rear indirect Blaze Basket grilling option

### Heat/Flue-way

Patent-pending rear flue-way channel which efficiently uses heat to cook food rather than get wasted heating up an enormous mass of ceramic clay

### Lid Opening Weight

10 lbs.— No spring needed

### Lid Seal Gasket

High temperature fiberglass woven cable with stainless steel bulb

### Efficiency Rating

9+ hours with average temperature of 225°F with one pound of fuel

### Outside Lid Temperature When Interior is 400°F

140°F (warm to touch)

### Product Assembly

Ships practically ready to grill— just 15 minutes to assemble cart to head and you're grilling/smoking

### Clean-Ability

Interior may be cleaned like oven, using self-cleaning sprays

### Thoughtful Details

The Pro Kamado comes in stainless steel or set colors (red, black or turquoise) and wood handle or side shelf upgrade options. A variety of cooking accessories available, too!

### TYPICAL CLAY KAMADO GRILL

1 1/2" thick solid clay that can crack

200+ lbs (you'll need 3 friends to help move it into the yard)

Not available

Direct vertical exit—inefficient by oven design standards

19 lbs. lift force required, even with spring mechanism installed = HEAVY

Glued on felt that has to be replaced if grill gets too hot

4 hours with average temperature of 225°F with one pound of fuel

225°F (HOT to touch)  
Keep the kids away!

Nearly 80 pieces and 15 pages of instructions to assemble the grill head alone with straps, nuts, bolts, brackets, etc.

A true "self-clean" claim requires 900°F temperature for 3 hours— not possible with ceramic grills

Most kamados come in one set color of red or green and no design options available. Also, not very many cooking accessory options made for other kamados



## CALIBER PRO KAMADO CHARCOAL GRILL/SMOKER ACCESSORIES

### Caliber Cauldera Iron Cooking Pot Kit (CTP22-CCA)

Includes Heavy Duty 304 Stainless Steel Pot locating rack and seasoned 14 Quart USA made Lodge™ Iron Cooking Pot.



### Build-In Leg Kit (CTPLK)

For use when building in a Caliber Pro Kamado Grill head into an outdoor island enclosure. This set includes 2 stainless steel metal pieces that mount to the bottom of the grill to space the grill off of the mounting surface for safe grilling.



### 1/2 Size Griddle Plate (CTPGD1-2)

Breakfast or Brunch on your grill is a breeze with the help of our 3/16" thick 304 Stainless Steel welded griddle plate.



### 3/4 Size Griddle Plate (CTPGD3-4)

Go Big with our largest griddle plate. Offers over 300 square inches of grilling space. Breakfast or brunch for the group is on with the help of our 3/16" thick 304 Stainless Steel welded griddle plate.



### Step Up Grill Rack (CTP-2XRACK)

When you need that extra space for grilling or warming your meals. Adds an extra 180 square inches of usable space inside the already large grilling cavity.

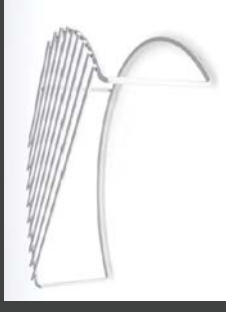

### Rib and Roast Rack (CTP-RIB-RACK)

Designed for your Caliber Pro Kamado Grill to accommodate 6 racks of ribs or reversible for a 10 lb. roast. Made with a dishwasher safe quality.



## CALIBER PRO KAMADO CHARCOAL GRILL/SMOKER ACCESSORIES

### Stainless Steel Cart/Side Shelf Kit (CTP22-C-SSW)

Includes Heavy Duty 304 Stainless Steel cart base plus 2 wood slat side shelves as shown

Side shelves—Shown assembled on our Stainless Steel Caliber Pro Kamado model CTP22-SS and Pro Kamado wood handle upgrade (CTP22WH)

### Stainless Steel Cart/ Stainless Steel Side Shelf Kit (CTP22-C-SS)

Includes Heavy Duty 304 Stainless Steel cart plus 2 all Stainless Steel Side shelves

Side shelves—Shown assembled onto our Turquoise Caliber Pro Kamado with Stainless Steel handle model CTP22-TQ

### 22" Caliber Pro Kamado Grill/Smoker (304 Stainless Steel with Stainless Steel Handle) (CTP22-SS)

Build your Caliber Pro Kamado into your outdoor cabinetry or island. Additional colors also available: black (CTP22-BK), red (CTP22-RD) and turquoise (CTP22-TQ). For safe grilling, please make sure to use the Build-In Leg Kit (CTPLK) and use Spec Sheet for proper installation

Available Colors:



### Perfect Pizza Kit (CTP22-PK)

Includes Heavy Duty 304 Stainless Steel pizza stone locating rack and commercial grade 3/4" thick Pizza Stone for pizza primo and better baking



### Rockin' Rotisserie Kit (CTP22-RK)

Includes side mount rotisserie motor (110V plug-in required), 12V transformer, Stainless Steel Rotisserie rod, and 2 rotisserie fork skewers



### Indirect Blaze Basket (CTP22-RB)

Enjoy Chiaroscuro style rear basket grilling with our 304 Stainless Steel construction —designed for use with the exclusive Caliber Rotisserie feature, or anytime you require indirect heat for your Caliber Pro Kamado

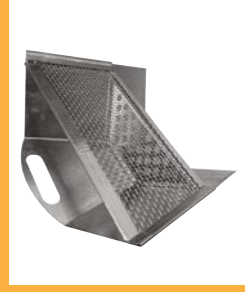

### Full Height Vinyl Cover (CTP22-V)

Protect your Caliber Pro Kamado Grill with our commercial grade vinyl protective cover



## ACCESSORIES



EXPECT  
GREAT  
HEAT™



[WWW.CALIBERAPPLIANCES.COM](http://WWW.CALIBERAPPLIANCES.COM)

As part of our ongoing product improvement process,  
Caliber Appliances reserves the right to change design,  
specifications and materials without notice.

© Caliber Appliances 2019  
P/N 34116 Rev.4/2019