



TRUE CALIBER™

ADA HEIGHT
15 INCH TRUE ICE® MACHINE
INSTALL GUIDE AND USER'S MANUAL



LUXURY REFRIGERATION WITH COMMERCIAL DNA



829074-E

THANK YOU

FOR YOUR PURCHASE



LUXURY REFRIGERATION WITH COMMERCIAL DNA



CONTENTS

INSTALLATION CHECKLIST	<u>6</u>	PRIOR TO INSTALLATION	
15 INCH TRUE ICE® MACHINE MODELS	<u>7</u>	ADA-COMPLIANT INSTALLATION ROUGH OPENING & PLAN VIEWS [32" (813 MM) OPENING]	<u>18</u>
SAFETY INFORMATION & OWNERSHIP			
FEATURES OF THE TRUE ICE® MACHINE	<u>10</u>	OPTIONAL INSTALLATION ROUGH OPENING & PLAN VIEWS [34-1/2" (877 MM) OPENING]	<u>21</u>
OWNERSHIP	<u>11</u>	CUSTOM OVERLAY PANEL SPECIFICATIONS	<u>26</u>
REFRIGERANT SAFETY & WARNING INFORMATION	<u>11</u>	ELECTRICAL INSTALLATION & SAFETY	<u>34</u>
SAFETY LABELS & LOCATIONS	<u>12</u>	PLUMBING REQUIREMENTS & INSTALLATION	<u>36</u>
BASIC SAFETY & WARNING PRECAUTIONS	<u>14</u>	INSTALLATION	
PROPER DISPOSAL OF THE CABINET	<u>14</u>	UNCRATING	<u>44</u>
CABINET LOCATION & SPECIFICATIONS	<u>15</u>	LEVELING LEGS	<u>46</u>
OUTDOOR USE	<u>15</u>	LEVELING	<u>46</u>
PRIVACY	<u>16</u>	KICKPLATE INSTALLATION	<u>46</u>
CONTACT US	<u>16</u>	CABINET SETUP	
		ICE SCOOP	<u>48</u>
		90° DOORSTOP INSTALLATION (OPTIONAL ACCESSORY)	<u>48</u>

CONTENTS

CABINET OPERATION

BEFORE OPERATING	<u>50</u>
BREAKER RESET	<u>50</u>
POWER SEQUENCE	<u>50</u>
ICE MAKING SEQUENCE	<u>51</u>
ELECTRONIC CONTROL OPERATION	<u>52</u>

GENERAL MAINTENANCE, CARE, & CLEANING

GENERAL MAINTENANCE	<u>60</u>
WATER FILTER REPLACEMENT	<u>61</u>
CONDENSER COIL CLEANING	<u>62</u>
APPLIANCE CARE & CLEANING	<u>64</u>
DESCALING & SANITIZING	<u>66</u>
INTERIOR COMPONENTS	<u>68</u>
WINTERIZING	<u>71</u>

SERVICING, REPLACING COMPONENTS & ADJUSTMENTS

SERVICING & REPLACING COMPONENTS	<u>74</u>
REVERSING DOOR	<u>74</u>
DOOR ADJUSTMENT	<u>77</u>
CONTACT US	<u>77</u>

WARRANTY

ADA-COMPLIANT WARRANTY STATEMENT	<u>79</u>
----------------------------------	---------------------------

INSTALLATION CHECKLIST

To ensure no part of the installation process has been overlooked, complete the checklist below.

- Has an authorized True dealer or licensed installer inspected stainless steel surfaces for imperfection?
(Cosmetic defects are covered by a limited 30-day warranty)
- Have all packaging materials been removed?
- Is the unit properly leveled with all leveling legs contacting the floor?
- Has the water filter been installed? Has the water supply been turned on?
- Have the water supply and drain connections been made?
- Is the water supply temperature always between 40-100°F (4.4-7.8°C)?
- Has the ice machine drain line been routed into an open drain with no more than 84" (2,133.36 mm) vertical rise for 3/8" O.D. tubing and no more than 100' (30.48 m) run?
- Has the water supply been turned on?
- Is the power cord plugged into a properly grounded three-prong outlet in accordance with all applicable electrical codes?
- Have all connections been checked for water leaks? If not, pour water directly into the ice storage bin to ensure drain pump operation and inspect for leaks.
- Were the ice maker and storage bin disinfected prior to use? If not, see Sanitizing Procedure (page [67](#)).
- Has the ice machine been turned on? During the initial fill, can you hear the water valve turn on and see water filling the reservoir tank?
- After the first ice cycle, did all 24 ice cubes fall into the bin during harvest?
- Have the first two batches of ice been discarded?
- Has the customer reviewed the unit's operation in this manual?
- Has the customer reviewed the schedule of maintenance of the machine?

15 INCH TRUE ICE® MACHINE MODELS

15" STAINLESS STEEL



TUIADA-15-RS/LS-A~S

15" OVERLAY PANEL



TUIADA-15-RS/LS-A~0

15" CUSTOM FINISH



TUIADA-15-RS-A~104-H04

CUSTOMIZE YOUR TRUE WITH
A VARIETY OF FINISH AND
HARDWARE OPTIONS AT

<https://true-residential.com/custom/>



FINISHES



HARDWARE

FEATURES OF THE TRUE ICE® MACHINE

OWNERSHIP

REFRIGERANT SAFETY & WARNING INFORMATION

SAFETY LABELS & LOCATIONS

BASIC SAFETY PRECAUTIONS & WARNINGS

PROPER DISPOSAL OF THE CABINET

CABINET LOCATION & SPECIFICATIONS

OUTDOOR USE

PRIVACY

CONTACT US



LUXURY REFRIGERATION WITH COMMERCIAL DNA

FEATURES OF THE TRUE ICE MACHINE

- Articulating, soft close hinge allows fully integrated, flexible installations.
- Produces up to 75lb (34kg) of clear ice per day with a storage capacity of 28lb (12.7kg).
- Bin Level Control for entertaining flexibility (50%, 65%, 70%, 85%, 100%).
- Patented TruLumina® LED lighting gently illuminates your product and allows you to choose from 14 different color options with the push of a button.
- Concealed digital control located behind toekick.
- Exclusive True Magna Scoop for easy storage on door.
- Industry exclusive, standard built-in drain pump.
- External water filter kit included – rated up to 1250 gallons.
- Automatic cleaning system.
- All undercounter models UL rated for outdoor use.
- Environmentally friendly R290 refrigerant.
- Energy Star rated.
- Industry-leading True Warranty.



PERFORMANCE SPECIFICATIONS

*Maximum Ice Capacity (lbs/day)	75lb (34kg) / day
**Rated Ice Capacity (lbs/day)	75lb (34kg) / day
**Rated Ice Storage (lbs)	28lb (12.7kg)
**Rated Energy Consumption (kWh/lbs)	6.65 kWh / 100 lbs
**Rated Water Consumption (Gal/lbs)	24.2 Gal / 100 lbs

*Performance rated at 70°F (21.1°C) air / 50°F (10°C) water / 30 psig (206.8 kPa) water pressure
 **Performance rated at 90°F (32.2°C) air / 70°F (21.1°C) water / 30 psig (206.8 kPa) water pressure

OWNERSHIP

To ensure that your unit works properly from the first day, it must be installed properly. We highly recommend a trained refrigeration mechanic and electrician install your True equipment. The cost of a professional installation is money well spent.

Before you start to install your TRUE unit, carefully inspect it for freight damage. IF DAMAGE IS DISCOVERED, DO NOT INSTALL THE UNIT OR PUT IT IN SERVICE. Notify True customer service, and immediately file a claim with the delivery freight carrier.

TRUE is not responsible for damage incurred during shipment.

For any questions about installation, please contact your True dealer or True Residential Technical Service at **844-746-9423** or **TrueResidentialService@TrueMfg.com**. Please have your model and serial number available.



WARNING! PROPER INSTALLATION REQUIRES A CONNECTION TO THE WATER SUPPLY, A DRAIN, AND A DEDICATED ELECTRICAL CIRCUIT. THESE CONNECTIONS ARE THE RESPONSIBILITIES OF THE INSTALLER. IMPROPER CONNECTIONS CAN RESULT IN PERSONAL INJURY, PROPERTY DAMAGE AND IMPROPER OPERATION. THE ICE MACHINE MUST BE INSTALLED ACCORDING TO ALL APPLICABLE NATIONAL, STATE AND LOCAL CODES AND REGULATIONS.

REFRIGERANT SAFETY & WARNING INFORMATION

This unit contains hydrocarbon refrigerant (R-290).



Please carefully and completely read all safety labels and the warnings below:

DANGER! Risk of fire or explosion. Flammable refrigerant used. DO NOT use mechanical devices to defrost refrigerator. DO NOT puncture refrigerant tubing; follow handling instructions carefully. To be repaired only by trained service personnel.



DANGER! Risk of fire or explosion (flammable refrigerant used), consult repair manual/owner's guide before attempting to service this product. All safety precautions must be followed. Dispose of properly in accordance with local and federal regulations. Follow all safety precautions.



CAUTION! Keep all ventilation openings clear of obstruction in the appliance enclosure or in the structure housing the appliance.

INFORMATIONS DE SÉCURITÉ ET D'AVERTISSEMENT CONCERNANT LE FRIGORIGÈNE

Consultez l'étiquette de numéro de série à l'intérieur de l'armoire pour connaître le type de réfrigération des appareils. Pour une réfrigération aux hydrocarbures seulement (R290), voir ci-dessous



DANGER! Risque de feu ou d'explosion. Le frigorigène utilisé est inflammable.
Ne PAS! utiliser des appareils mécaniques pour dégivrer le réfrigérateur.
Ne PAS! percer les tuyaux de réfrigérant ; suivre scrupuleusement les instructions de manutention. Les réparations doivent être effectuées seulement par un technicien qualifié.



DANGER! Risque d'incendie ou d'explosion (réfrigérant inflammable utilisé), consultez le manuel de réparation/guide d'utilisation avant toute tentative d'intervention sur ce produit. Toutes les mesures de sécurité doivent être respectées. Mettez au rebut conformément aux règlements fédéraux ou locaux. Respectez toutes les précautions de sécurité.



ATTENTION! Éviter toute obstruction des ouvertures de ventilation dans la pièce où l'armoire est située ou sur l'armoire elle-même.

SAFETY LABELS & LOCATIONS

Your new ice maker has labels placed in specific locations throughout the cabinet which identify important safety information. Please take a moment to familiarize yourself with the content and label locations.



FIG. 1. Example of safety label locations. Not all labels or locations shown.

ON THE REAR PANEL

	⚠ WARNING
	RISK OF FIRE OR EXPLOSION. DISPOSE OF PROPERLY IN ACCORDANCE WITH FEDERAL OR LOCAL REGULATIONS. FLAMMABLE REFRIGERANT USED.
	⚠ ATTENTION
	RISQUE DE FEU OU D'EXPLOSION. ÉLIMINER CONFORMÉMENT AUX RÈGLEMENTS FÉDÉRAUX OU LOCAUX. LE FRIGORIGÈNE EST INFLAMMABLE.

PART # 224556

	⚠ CAUTION
	RISK OF FIRE OR EXPLOSION DUE TO PUNCTURE OF REFRIGERANT TUBING; FOLLOW HANDLING INSTRUCTIONS CAREFULLY. FLAMMABLE REFRIGERANT USED.
	⚠ CAUTION
	RISQUE DE FEU OU D'EXPLOSION SI LA TUBULURE CONTENANT LE FRIGORIGÈNE EST PERFORÉE. SUIVRE LES INSTRUCTIONS DE MANUTENTION AVEC SOIN. LE FRIGORIGÈNE EST INFLAMMABLE.

PART # 224553

	⚠ CAUTION
	HAZARDOUS MOVING PARTS Moving parts can cut. Keep hands clear when panels removed.
	⚠ ATTENTION
	PIÈCES EN MOUVEMENT DANGEREUSES Ils peuvent couper. Tenir les mains à l'écart quand panneaux retirés.

PART # 972946

	⚠ WARNING
	HAZARDOUS VOLTAGE Risk of electric shock. Disconnect power before servicing the unit.
	⚠ ADVERTISSEMENT
	DANGEREUX TENSION Débrancher l'alimentation avant de procéder à l'entretien de l'unité.

PART # 972948

INSIDE THE COMPRESSOR COMPARTMENT

	⚠ DANGER
	RISK OF FIRE OR EXPLOSION. FLAMMABLE REFRIGERANT USED. TO BE REPAIRED ONLY BY TRAINED SERVICE PERSONNEL. DO NOT PUNCTURE REFRIGERANT TUBING.
	⚠ DANGER
	RISQUE DE FEU OU D'EXPLOSION. LE FRIGORIGÈNE EST INFLAMMABLE. CONFIER LES RÉPARATIONS À UN TECHNICIEN SPÉCIALISÉ. NE PAS PERFORER LA TUBULURE CONTENANT LE FRIGORIGÈNE.

PART # 224559

	⚠ CAUTION
	HAZARDOUS MOVING PARTS Moving parts can cut. Keep hands clear when panels removed.
	⚠ ATTENTION
	PIÈCES EN MOUVEMENT DANGEREUSES Ils peuvent couper. Tenir les mains à l'écart quand panneaux retirés.

PART # 972946

	⚠ CAUTION
	RISK OF FIRE OR EXPLOSION. FLAMMABLE REFRIGERANT USED. CONSULT REPAIR MANUAL / OWNER'S BEFORE ATTEMPTING TO SERVICE THIS PRODUCT. ALL SAFETY PRECAUTIONS MUST BE FOLLOWED.
	⚠ CAUTION
	RISQUE DE FEU OU D'EXPLOSION. LE FRIGORIGÈNE EST INFLAMMABLE. CONSULTER LE MANUAL DU PROPRIÉTAIRE / GUIDE DE RÉPARATION AVANT DE TENTER UNE RÉPARATION. TOUTES LES MESURES DE SÉCURITÉ DOIVENT ÊTRE RESPECTÉES.

PART # 224555

BENEATH THE EVAPORATOR COVER'S TOP PANEL

	⚠ DANGER
	RISK OF FIRE OR EXPLOSION. FLAMMABLE REFRIGERANT USED. DO NOT USE MECHANICAL DEVICES TO DEFROST ICE MACHINE. DO NOT PUNCTURE REFRIGERANT TUBING.
	⚠ DANGER
	RISQUE DE FEU OU D'EXPLOSION. LE FRIGORIGÈNE EST INFLAMMABLE. NE PAS UTILISER D'APPAREILS MÉCANIQUES POUR DÉGIVRER LA MACHINE À GLACE. NE PAS PERFORER LA TUBULURE CONTENANT LE FRIGORIGÈNE.

PART # 224657

BASIC SAFETY & WARNING PRECAUTIONS

- Take care during operation, maintenance or repairs to avoid cuts or pinching from any part/component of the cabinet.
- Units may pose a tipping hazard while uncrating, during installation, or when moving the unit.
- Ensure the unit is properly installed and located in accordance with the Installation Instructions before use.
- This appliance is not to be used, cleaned or maintained by persons (including children) with reduced physical, sensory or mental capabilities or lack of experience and knowledge, unless they have been given supervision or instruction.
- **DO NOT** allow children to play with the appliance or climb, stand, or hang on the unit's shelves to prevent damage to the refrigerator and personal injury.
- **DO NOT** touch the cold surfaces in the freezer compartment when hands are damp or wet. Skin may stick to these extremely cold surfaces.
- Unplug the ice maker before cleaning and making repairs.
- Powering off the ice maker will not remove power from all components (e.g., light circuit and drain pump).
- **DO NOT** store or use gasoline, or other flammable vapors and liquids, in the vicinity of this or any other appliance.
- **DO NOT** store explosive substances such as aerosol cans with a flammable propellant in this appliance.
- Keep fingers out of the "pinch point" areas; clearances between the doors and cabinet are necessarily small; be careful closing doors when children are in the area.

- **DO NOT** use electrical appliances inside the food storage compartments of the units unless the appliances are of the type recommended by the manufacturer.

NOTE: ALL SERVICING MUST BE PERFORMED BY A QUALIFIED TECHNICIAN.

PROPER DISPOSAL OF THE CABINET



DANGER! RISK OF CHILD ENTRAPMENT

Child entrapment and suffocation are not problems of the past. Junked or abandoned appliances are still dangerous, even if they will sit for "just a few days." If you are getting rid of your old appliance, please follow the instructions below to help prevent accidents.

Before throwing away your old ice machine:

Take off the door.



DANGER – Risk of fire or explosion.

Flammable insulation and/or refrigerant used. Dispose of all in accordance with local and federal regulations. Follow all safety precautions.



DANGER – Risque de feu ou d'explosion.

Isolation et/ou réfrigérant inflammable utilisé. Toujours mettre au rebut conformément aux règlements fédéraux ou locaux. Respectez toutes les précautions de sécurité.

CABINET LOCATION & SPECIFICATIONS

For more information regarding the installation location or cabinet specifications, please see "Prior to Installation" starting on page [17](#).

- Appliance is Certified to NSF Standard 12.
- Appliance is UL rated for outdoor use.
- Appliance is not suitable for an area where a pressure washer or hose may be used.
- Ensure the location will provide adequate clearances and sufficient airflow for the cabinet.
- Ensure the power supply for the cabinet matches the cabinet specification sheet or cabinet data plate and is within the rated voltage ($\pm 5\%$) Also, ensure the amperage rating of the circuit is correct and the circuit is properly grounded.
- The cabinet should always be plugged into its own individual dedicated electrical circuit. The use of adapter plugs and extension cords is prohibited.

SERIAL LABEL LOCATION

Your serial label contains important information such as your model and serial number. The label is located on the upper left interior wall.

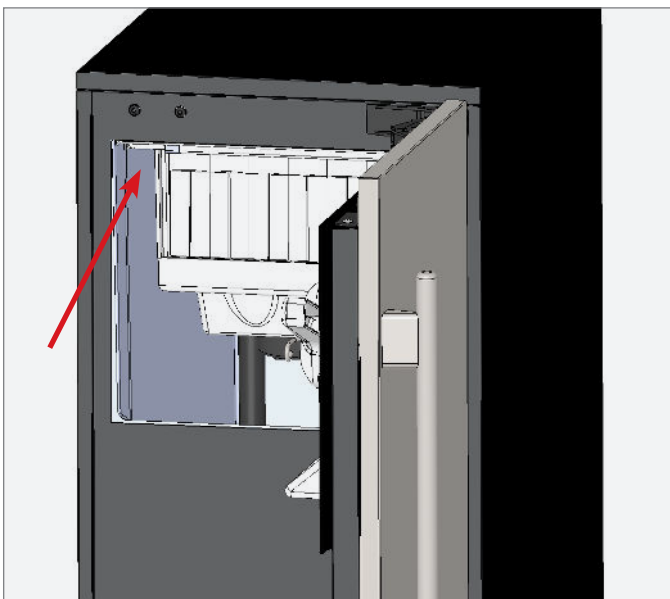

OUTDOOR USE

All True undercounter ice machines are rated for outdoor use.

- The unit must be covered or otherwise protected from direct exposure to rain.
- For the safest possible outdoor installation, build the unit into an undercounter kitchenette area within stone, brick, wood, etc.
- If the unit is expected to be exposed to low air temperatures for a prolonged period of time, please turn the unit off and winterize the unit. See "Winterizing" (page [71](#)).



NOTICE! DO NOT ALLOW THE ICE MACHINE TO BE EXPOSED TO TEMPERATURES BELOW 32°F (0°C) WITHOUT WINTERIZING THE UNIT AS THIS WILL CAUSE ANY WATER IN THE MACHINE TO FREEZE. FAILURES CAUSED BY EXPOSURE TO FREEZING TEMPERATURES ARE NOT COVERED BY THE WARRANTY.

PRIVACY

As of January 2026, your True Clear Ice Machine is equipped with **smart** technology that transmits limited usage performance and activity data (UPAD)—such as performance metrics, operating status, and diagnostic information—to us here at True. This data is used solely to enable True to provide you with faster service and support, and assists with continual product improvements.

No personal data or personally identifying information is collected as part of the UPAD from your True Clear Ice Machine. The UPAD collected is limited to the functioning of your True Clear Ice Machine. Only upon your registration of your machine is your UPAD associated with your personal data or personal information.

For more details, please refer to our privacy policy at <https://true-caliber.com/privacy-policy/>.

CONTACT US

For any questions about installation, please contact your TRUE dealer or TRUE Residential Technical Service. Please have your model and serial number (see serial label location below) available so we can better assist you with your service- or parts-related inquiries.

Customer Service

Phone: 888-616-8783
info@true-residential.com

Warranty Department

Phone: 844-849-6179
TrueResidentialWarranty@truemfg.com

Technical Service Department

Phone: 844-746-9423
TrueResidentialService@truemfg.com

ADA-COMPLIANT INSTALLATION ROUGH OPENING & PLAN VIEWS
[32" (813 MM) OPENING]

OPTIONAL INSTALLATION ROUGH OPENING & PLAN VIEWS
[34-1/2" (877 MM) OPENING]

CUSTOM OVERLAY PANEL SPECIFICATIONS

CUSTOM OVERLAY PANEL INSTALLATION

ELECTRICAL SAFETY & INSTALLATION



LUXURY REFRIGERATION WITH COMMERCIAL DNA

PRIOR TO INSTALLATION

ALLOWABLE AIR TEMPERATURES

	Air Temperature	Water Temperature	Water Pressure
Minimum	40°F (4.4°C)	40°F (4.4°C)	20 psig (1.4 bar)
Maximum	100°F (37.8°C)	100°F (37.8°C)	80 psig (5.5 bar)

ADA-COMPLIANT INSTALLATION ROUGH OPENING & PLAN VIEWS [32" (813 MM) OPENING]

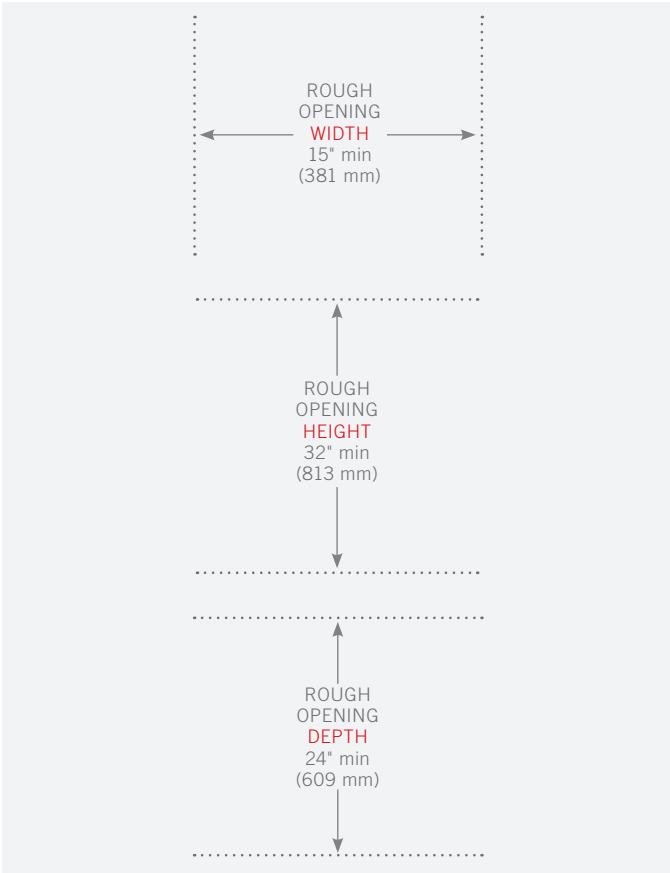

Avoid running wires or plumbing in this area.

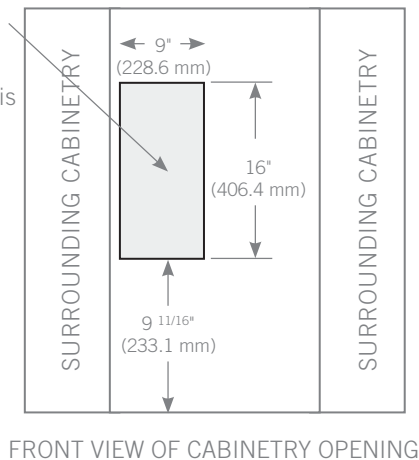

ANTI-SWEAT FOAM END PANELS

When installing two or more True units side-by-side, be sure to leave at least a 5/8" (15.88 mm) gap between the cabinets, or install foam pads between the cabinets and on any side without this gap, to prevent moisture from developing on applications.

If installing anti-sweat foam end panels, True recommends applying a panel to each of the units being joined together. To order foam pads, contact our parts department at **844-849-6226** or TrueResidentialParts@TrueMfg.com.

WATER LINE, DRAIN LINE, AND POWER CORD LOCATIONS

The ice maker must be installed with adequate clearance for water and drain connections at the rear of the unit. For plumbing specifications, please see "Plumbing Requirements & Installation" (page 36).

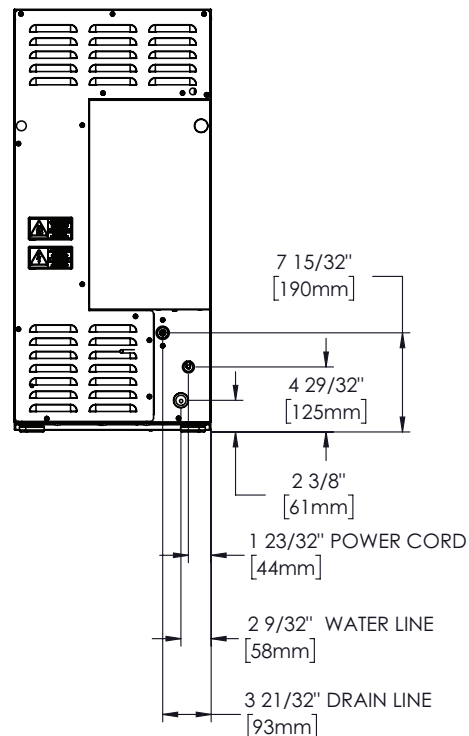

STAINLESS & FINISHED SOLID UNITS

STAINLESS STEEL DOOR



TUIADA-15-RS/LS-A~S

CUSTOM FINISH (DSK)

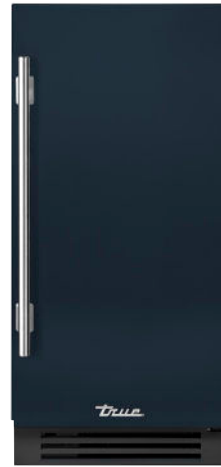

TUIADA-15-RS-A~104-H04

PLAN VIEW DIMENSIONS

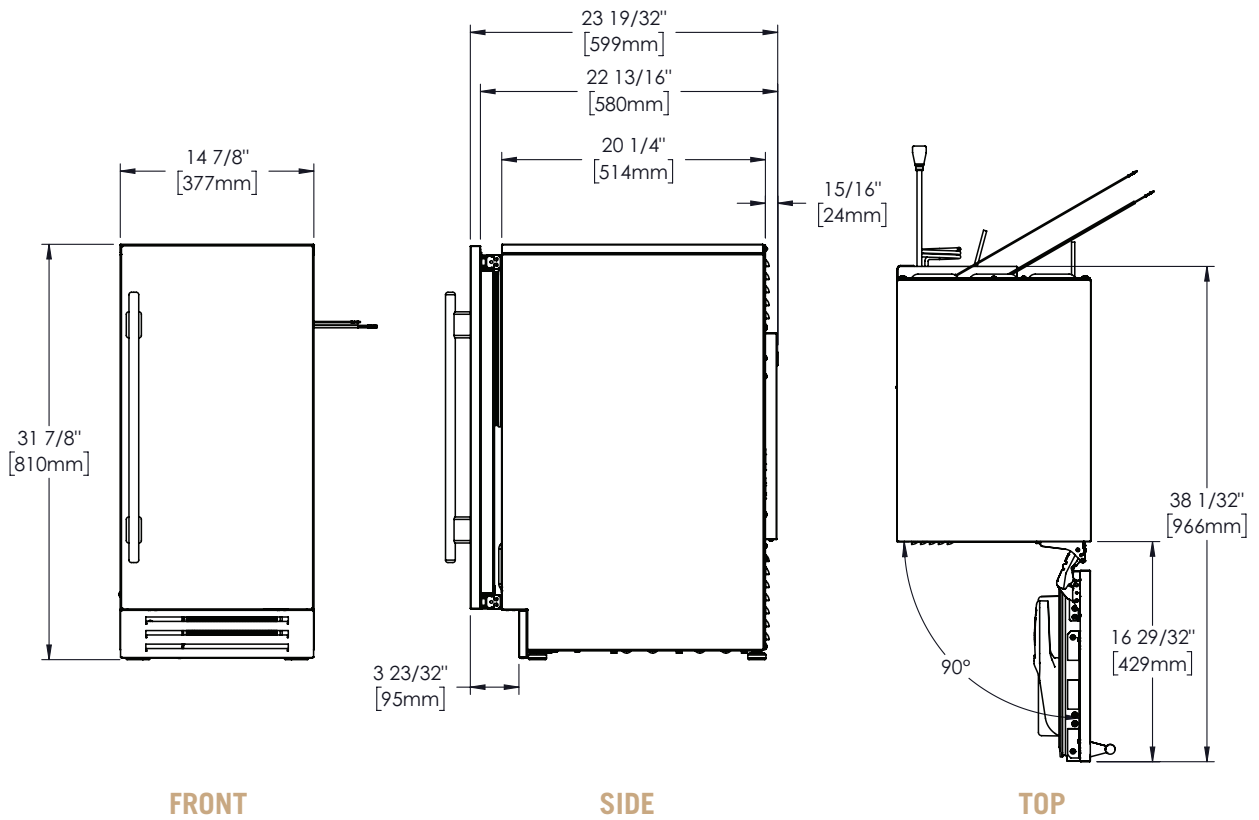

Dimensions may vary by $\pm 1/8$ " (3.2 mm)

SOLID OVERLAY UNITS

SOLID PANEL-READY DOOR (OP)



TUIADA-15-RS/LS-A~0

NOTE: Unit shown with overlay panel provided by others.

PLAN VIEW DIMENSIONS*

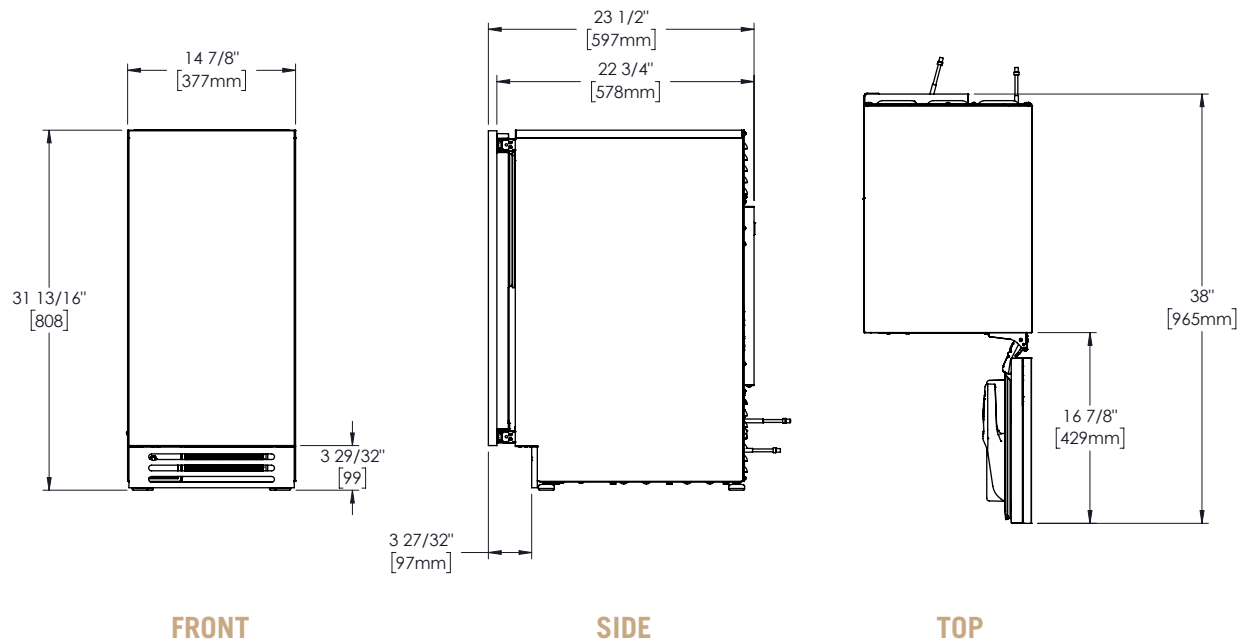

Dimensions may vary by $\pm 1/8$ " (3.2 mm) *Depth measurement includes $3/4$ " (19 mm) thick panel (not provided by True)

OPTIONAL INSTALLATION

ALLOWABLE AIR TEMPERATURES

	Air Temperature	Water Temperature	Water Pressure
Minimum	40°F (4.4°C)	40°F (4.4°C)	20 psig (1.4 bar)
Maximum	100°F (37.8°C)	100°F (37.8°C)	80 psig (5.5 bar)

OPTIONAL INSTALLATION ROUGH OPENING & PLAN VIEWS [34-1/2" (877 MM) OPENING]

Optional installations use combinations of 2-1/2" (64 mm) leveling legs, 6" (153 mm) grill, and custom overlay panels to raise (or appear to raise) the overall height of the unit. This section shows the cabinet specifications for the following configurations:

- A. 2-1/2" leveling legs and 6" grill (stainless steel unit)
- B. 2-1/2" leveling legs, 6" grill, and standard door overlay panel
- C. 2-1/2" leveling legs, 6" grill, and tall door overlay panel.
- D. Standard leveling legs and tall door overlay panel.

OPTIONAL INSTALLATION ROUGH OPENING

Please see the recommended dimensions for a nonstandard rough opening below. The height includes 2-1/2" (64 mm) leveling legs in the measure. For unit specifications, please see Optional Installation Plan Views starting on page [23](#).

ANTI-SWEAT FOAM END PANELS

When installing two or more True units side-by-side, be sure to leave at least 5/8" (16 mm) gap between the cabinets, or install foam pads between the cabinets and on any side without this gap, to prevent moisture from developing on applications.

If installing ant-sweat foam end panels, True recommends applying a panel to each of the

units being joined together. To order foam pads, contact our parts department at **844-849-6226** or TrueResidentialParts@TrueMfg.com.

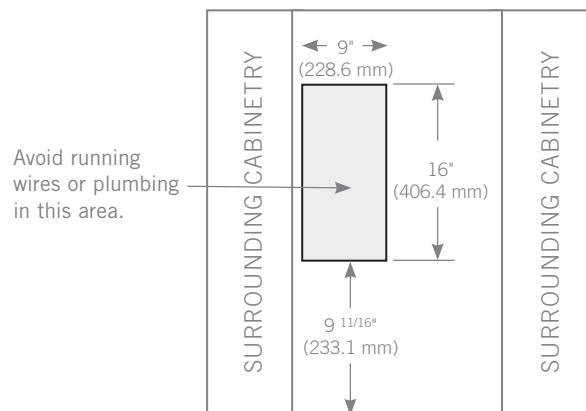
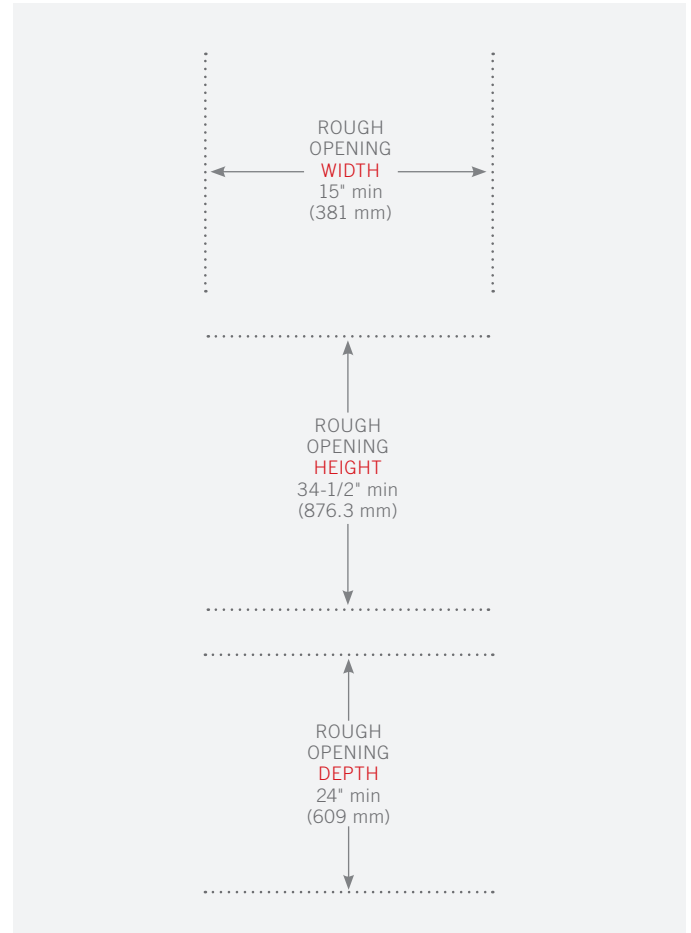

FRONT VIEW OF CABINETRY OPENING

OPTIONAL INSTALLATION

WATER LINE, DRAIN LINE, AND POWER CORD LOCATIONS

The ice maker must be installed with adequate clearance for water and drain connections at the rear of the unit.

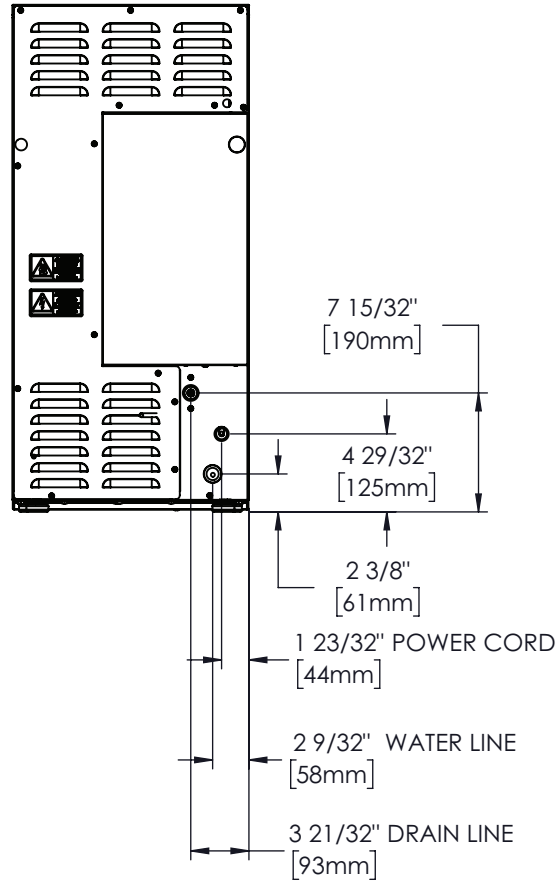

OPTIONAL INSTALLATION PLAN VIEWS

A & B. 2-1/2" (64 MM) LEVELING LEGS WITH 6" (153 MM) GRILL AND STANDARD DOOR (OVERLAY PANEL)

To order a 6" (153 mm) grill (stainless steel or black) or the 2-1/2" (64 mm) leveling legs please contact our parts department at **844-849-6226** or **TrueResidentialParts@TrueMfg.com**. For custom panel specifications, please see "Custom Overlay Panel Specifications" starting on page **26**.



TUIADA-15-RS/LS-A~0

PLAN VIEW DIMENSIONS*

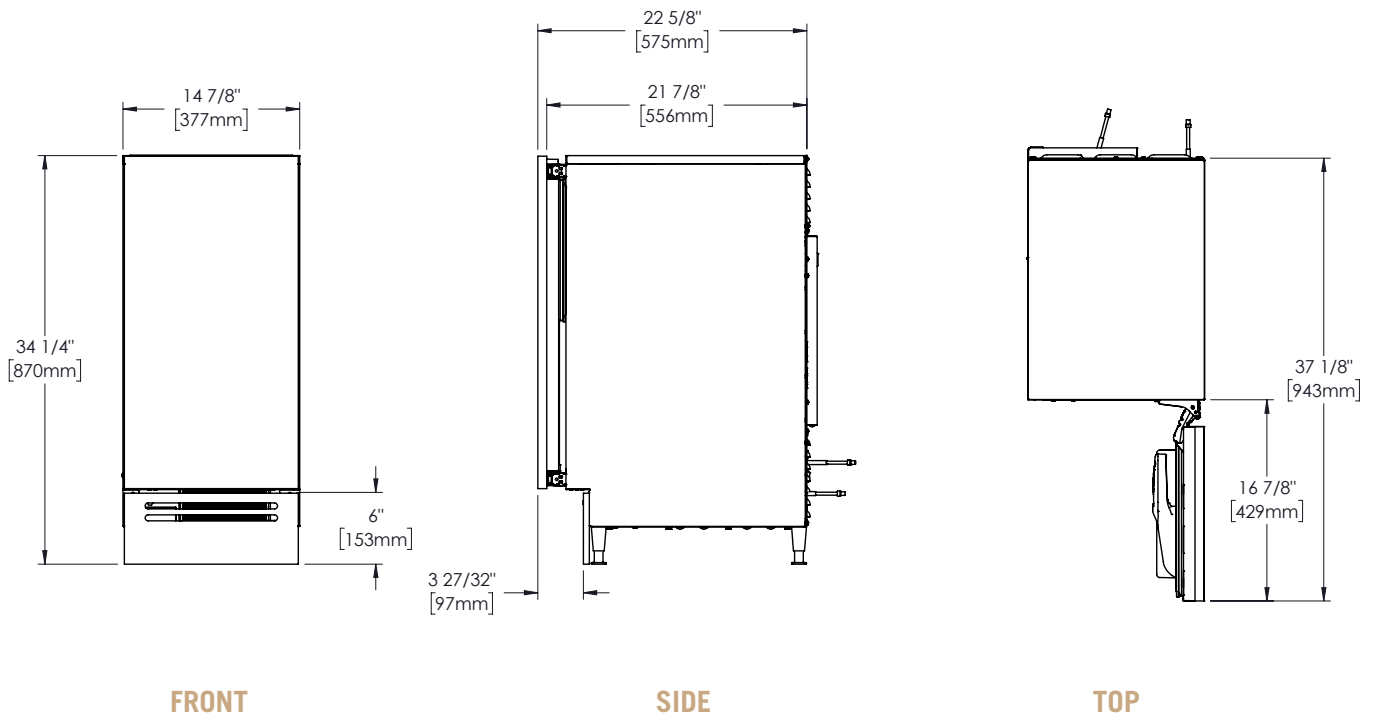

Dimensions may vary by ± 1/8" (3.2 mm) *Depth measurement includes 3/4" (19 mm) thick panel (not provided by True)

OPTIONAL INSTALLATION PLAN VIEWS

C. 2-1/2" (64 MM) LEVELING LEGS WITH 6" (153 MM) GRILL AND TALL DOOR OVERLAY PANEL (DOOR EXTENDS DOWN)

To order a 6" (153 mm) grill (stainless steel or black) or the 2-1/2" (64 mm) leveling legs please contact our parts department at **844-849-6226** or **TrueResidentialParts@TrueMfg.com**. For custom panel specifications, please see "Custom Overlay Panel Specifications" starting on page **26**.



TUIADA-15-RS/LS-A~0

NOTE: Unit shown with overlay panel provided by others.

PLAN VIEW DIMENSIONS*

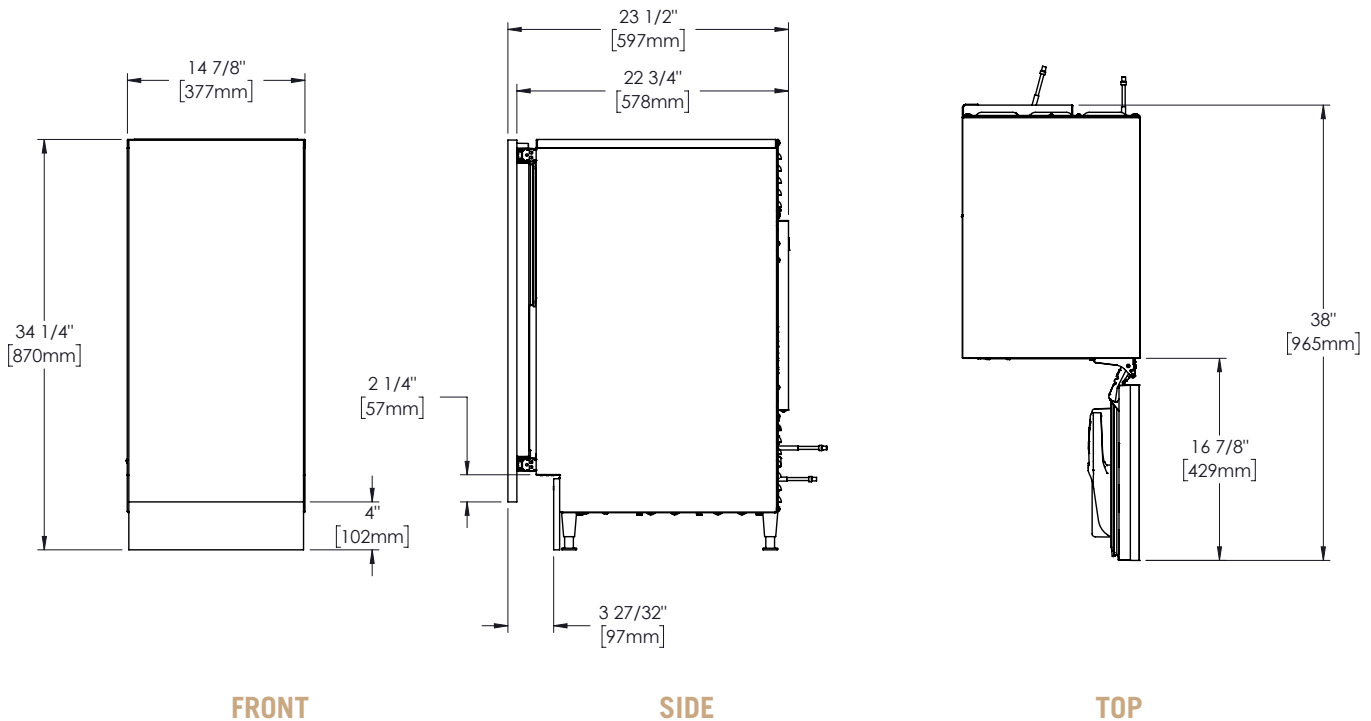

Dimensions may vary by ± 1/8" (3.2 mm) *Depth measurement includes 3/4" (19 mm) thick panel (not provided by True)

OPTIONAL INSTALLATION PLAN VIEWS

D. STANDARD LEVELING LEGS WITH TALL DOOR OVERLAY PANEL (DOOR EXTENDS UP)

For custom panel specifications, please see "Custom Overlay Panel Specifications" starting on page [26](#).



TUIADA-15-RS/LS-A~0

PLAN VIEW DIMENSIONS

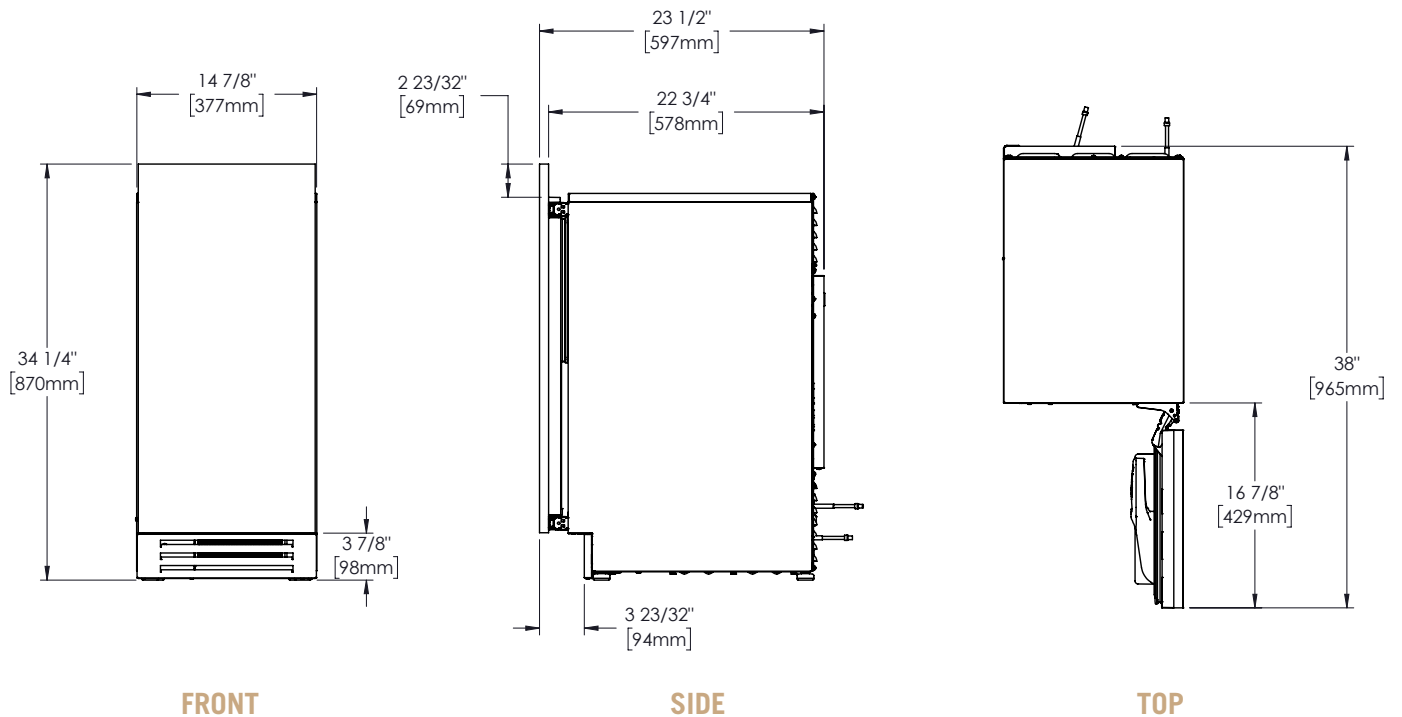

*Measures include 3/4" (19 mm) thick panel (not provided by True) Dimensions may vary by ± 1/8" (3.2 mm)

CUSTOM OVERLAY PANEL SPECIFICATIONS

Overlay units can be fitted with custom panels to match adjacent cabinetry. Please see this section for recommended panel specifications.

NOTE! PANEL HEIGHT CAN EXCEED THESE RECOMMENDATIONS BASED ON ROUGH OPENING SIZE AND CABINET SPECIFICATIONS.

True units assume 3/4" (19 mm) thick overlay panels of the specified width (see specifications tables) to be supplied by the end user or others. Thicker/wider panels increase the potential for panel interference. See fig. 1.

NOTE! THIS INTERFERENCE CAN BE MINIMIZED WITH A 90° DOORSTOP. SEE "90° DOORSTOP INSTALLATION" (PAGE 48).

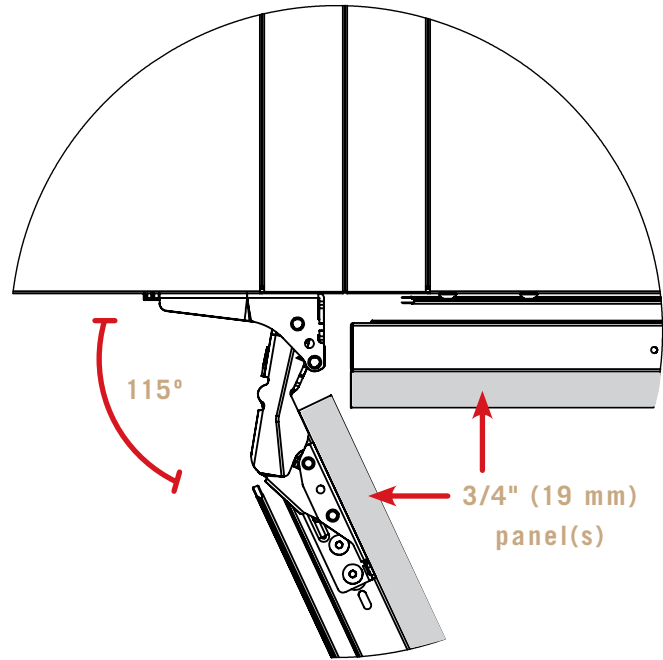

FIG. 1. Panels 3/4" (19 mm) thick are designed to not interfere with surrounding units or cabinetry.

PRIOR TO INSTALLATION

STANDARD SOLID DOOR OVERLAY PANEL - OPTIONAL INSTALLATIONS A & B

For panel installation instructions, please see "Custom Overlay Panel Installation" (page [32](#)).



Specifications	
Panel Width	14-5/8" (371.5 mm)
Panel Height	27-7/8" (708 mm)
Panel Depth	3/4" (19 mm) max
Panel Weight	10lb (4.5kg) max
Rail Style Dimension	2" (50.8 mm) min

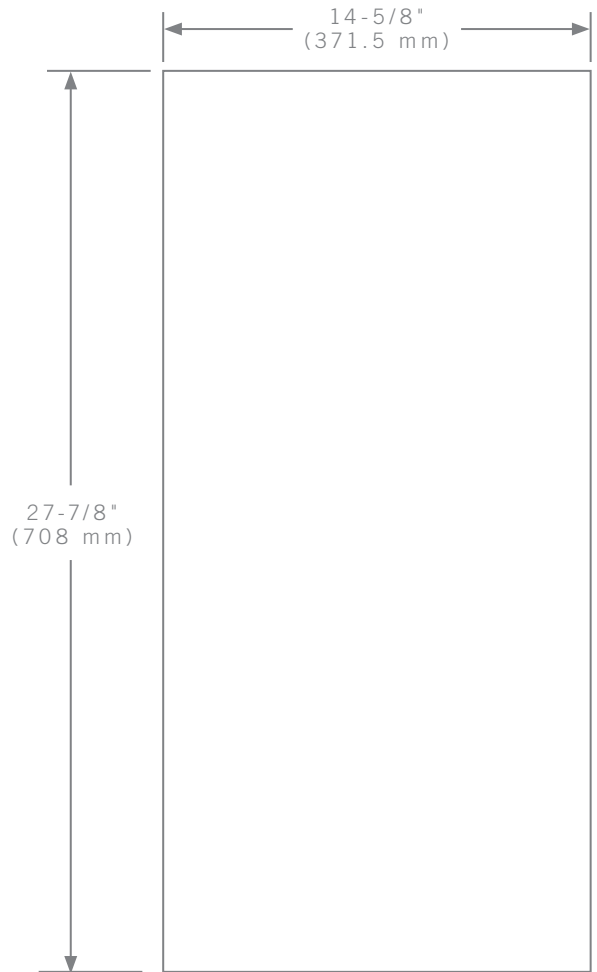

TALL DOOR OVERLAY PANEL – OPTIONAL INSTALLATIONS C & D

Overlay units can be fitted with custom panels to match adjacent cabinetry. For example, the tall door overlay panel can extend the apparent height of the unit or disguise the actual height of a 6" (600 mm) grill. For more detail, please see "Optional Installations Rough Opening & Plan Views" starting on page 21. Please see below for panel specifications.

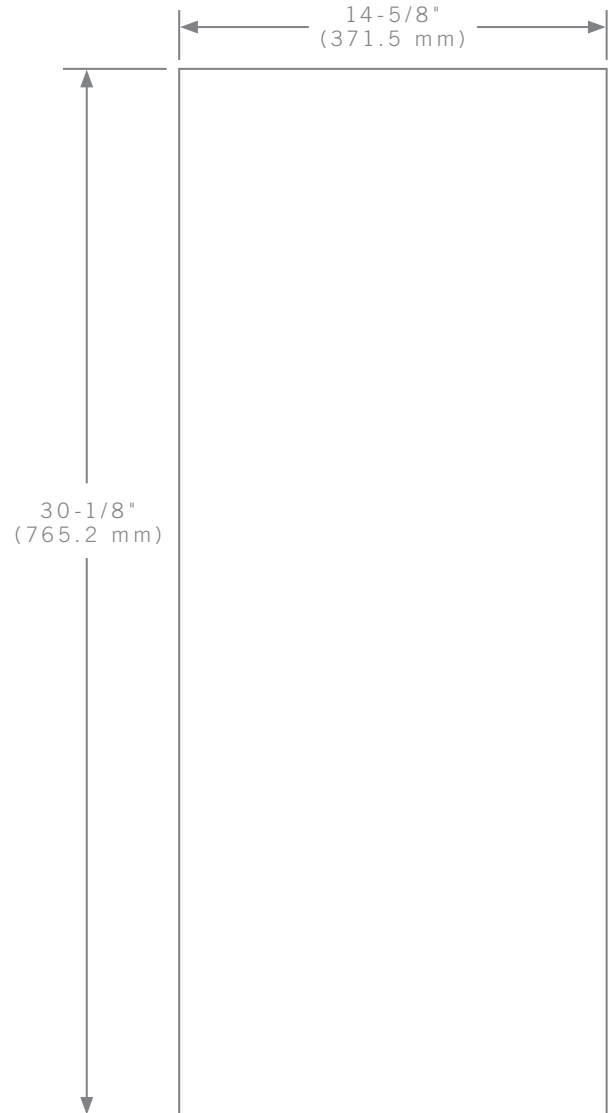

SPECIFICATIONS

Panel Width	14-5/8" (371.5 mm)
Panel Height	30-1/8" (765.2 mm)
Panel Depth	3/4" (19 mm) max
Panel Weight	10lb (4.5kg) max
Rail Style Dimension	2" (50.8 mm) min

PRIOR TO INSTALLATION

6" (153 MM) OVERLAY LOUVER GRILL TEMPLATE – OPTIONAL INSTALLATIONS A , B, & C

2-1/2" (64 mm) leveling legs create a visible gap between the bottom of the grill and the floor. To conceal this gap with overlay, please see the custom overlay louver grill template below.

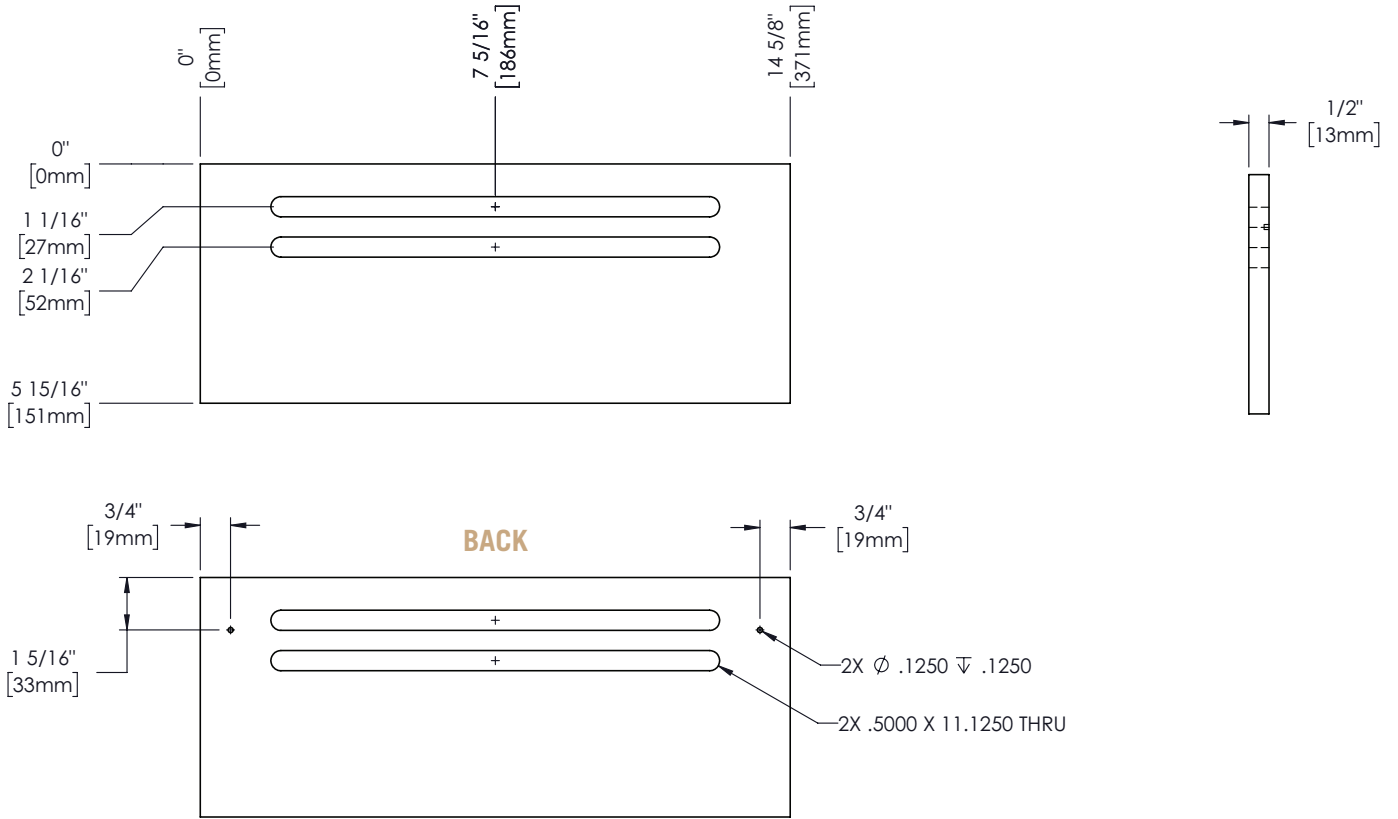

PRIOR TO INSTALLATION

4" (102 MM) STANDARD OVERLAY LOUVER GRILL TEMPLATE –
OPTIONAL INSTALLATION D

If so desired, you can replace the kickplate with a custom overlay louver grill. Please see the template below.

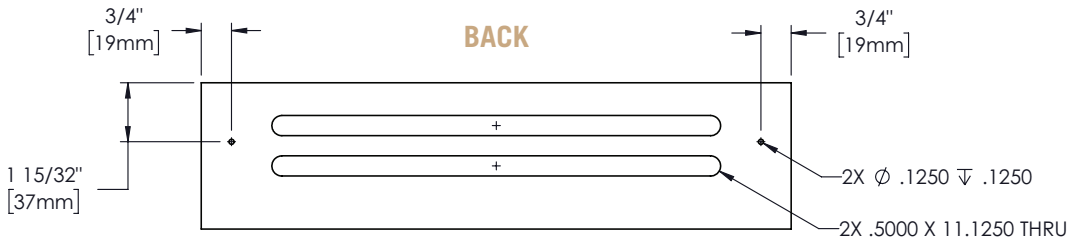
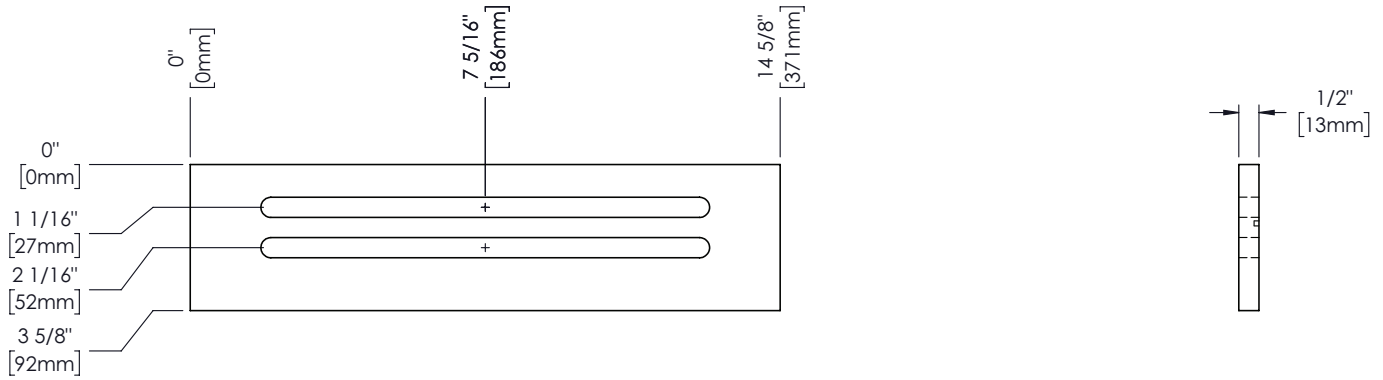

ADDITIONAL DOOR OVERLAY PANEL INFORMATION

- Custom door overlay panels must be at least 14-5/8" (375.1 mm) x 23-13/16" (605.1 mm) x 3/4" (19 mm) to cover the panel-ready door front. Your panel dimensions may vary based on the rough opening size and / or adjacent cabinetry specifications.
- For correct hinge operation, be sure to install door overlay panels with its hinge side aligned flush with the door front's hinge side.
- Doors have pre-drilled holes to assist overlay panel installation. See fig. 1.

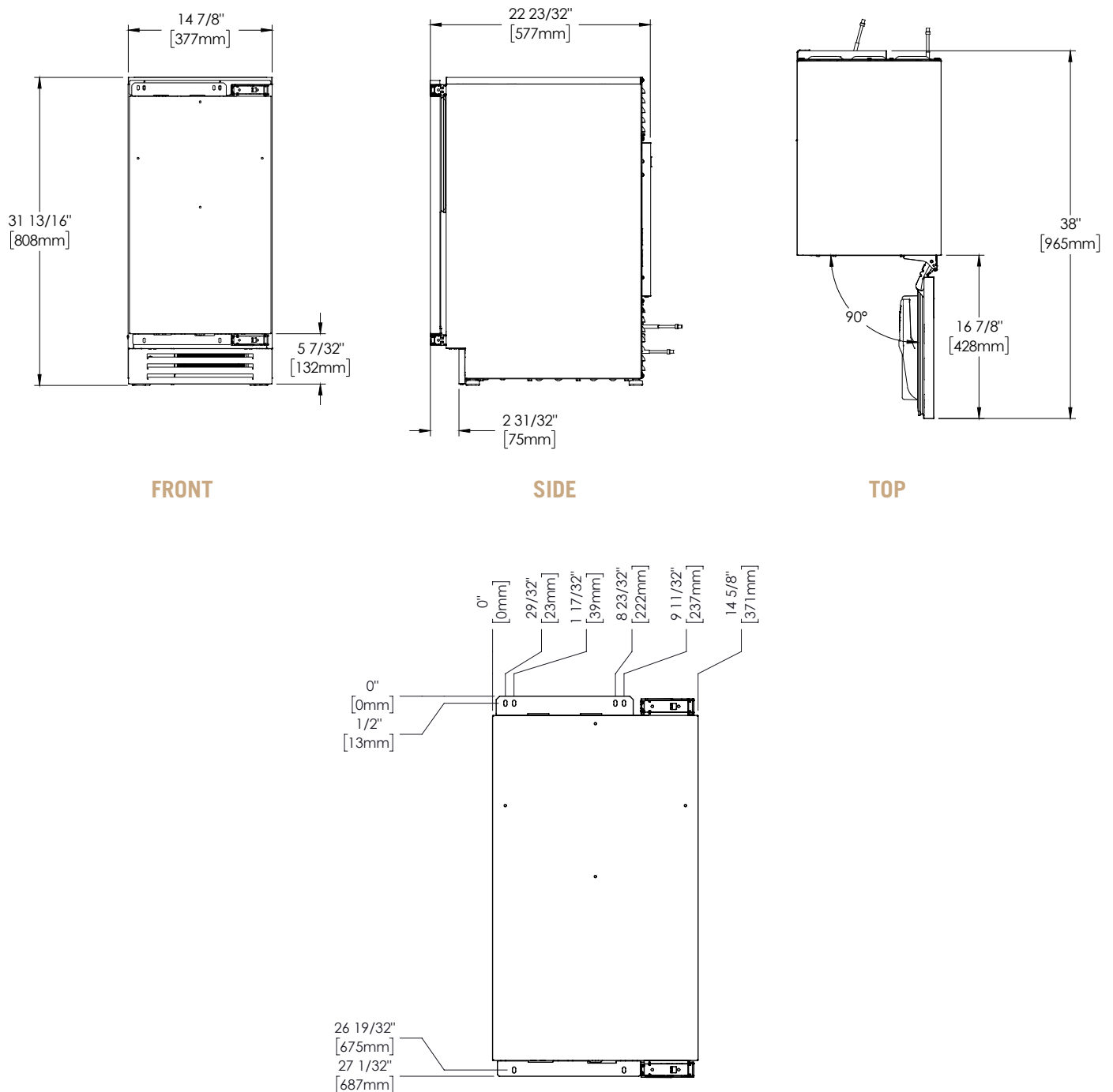

FIG. 1. Door front bracket hole and pre-drilled hole locations and measurements

CUSTOM OVERLAY PANEL INSTALLATION

Your new ice machine comes with articulating, or soft-closing, hinges. The hinges can be installed on either the left or right to change the direction the door opens. Before installing panels, be sure the door assembly is oriented as desired. See "Reversing Door" (page [74](#)). Please closely read all instructions before installing your panels.

REQUIRED TOOLS

Required tools include (but may not be limited to) the following.

- Surface protection*
- 2+ Clamps \geq 2" (51 mm)
- 1/8" Hex Head Allen Wrench
- Phillips Screwdriver or Bit Driver
- 1/8" Drill Bit
- (Qty 6) #6 x 1/2" Screws**
- Drill

*Cardboard, moving blanket, foam padding, etc.

**Screw type varies by panel material.

PROCEDURE

1. Carefully lay the door overlay panel face down on a protected surface.
2. With a 1/8" hex head Allen wrench, loosen the cabinet hinge bolts. Then, remove the door. See fig. 1.
NOTE: DO NOT REMOVE THE HINGE FROM THE DOOR ASSEMBLY.
3. If NSF Cover is present, carefully pry screw caps from the cover to access the door bracket screws. See fig. 2.
4. Place the door front face down on the overlay panel. Then, align the bottom door bracket's bottom edge with the overlay panel's bottom edge. See figs. 3 and 4.
5. Clamp the door assembly panel.
NOTE: IF THE CLAMP JAWS ARE NOT PADDED, INSERT PADDING BETWEEN THE CLAMP AND THE OVERLAY TO PROTECT THE PANEL'S FINISH.
6. If desired, install a handle before proceeding to the next step. For best installation, fasten the handle with recessed screws.
7. With a 1/8" drill bit, carefully drill pilot holes into the door front. See fig. 5.
NOTE: TAKE CARE TO NOT DRILL THROUGH THE FRONT OF THE PANEL.
8. With the appropriate hardware, fasten the overlay panel to the door front. Then, remove the clamps.
9. Install the door assembly. Be sure to fully tighten the hinge screws.
10. Verify the door closes correctly and seals without gaps. Adjust the door as needed; see "Door Adjustment" (page [77](#)).

PRIOR TO INSTALLATION

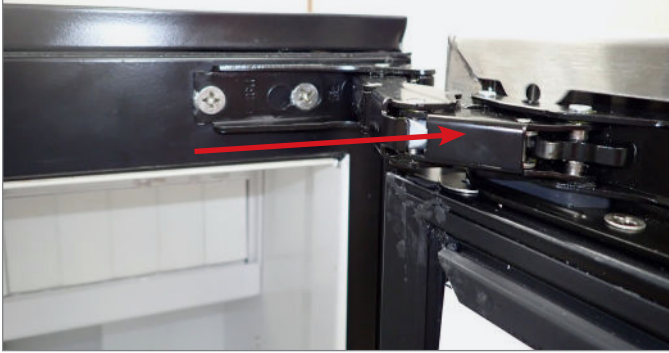

FIG. 1. Slide the door off the hinge bolts through the keyhole slots.

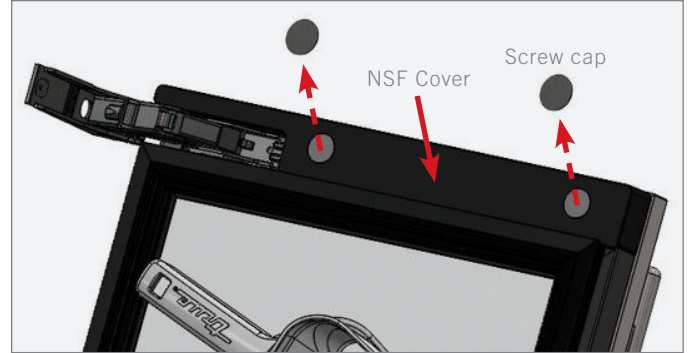

FIG. 2. Remove the NSF cover screw caps.



FIG. 3. Align along the bottom door bracket edge. Front of door assembly shown.

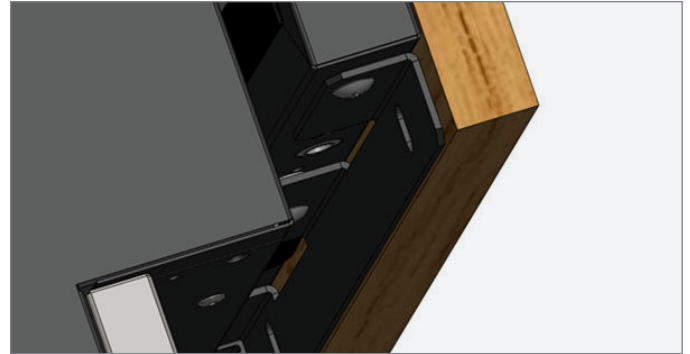

FIG. 4. The bottom edge of the panel should align with the bracket as shown.

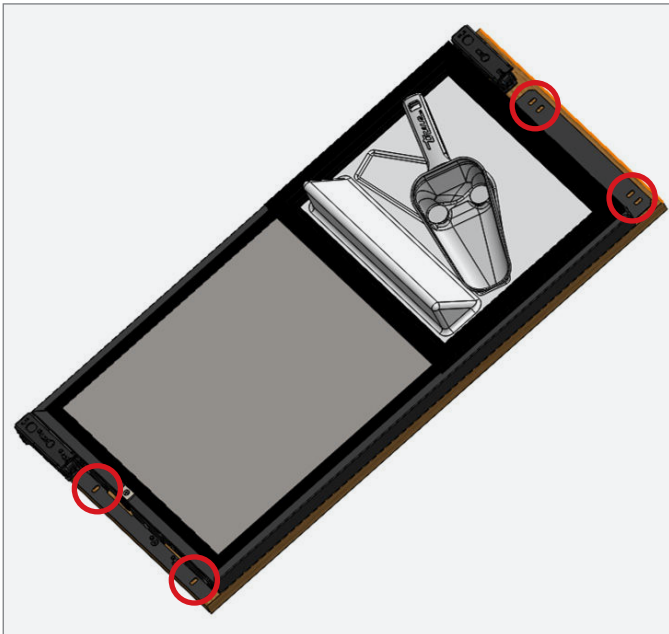

FIG. 5. Carefully fasten the overlay panel to the door front.

ELECTRICAL INSTALLATION & SAFETY

The unit is approved by UL for outdoor installation.

USE OF ADAPTER PLUGS

NEVER USE AN ADAPTER PLUG! An adapter plug alters the original OEM plug configuration when connecting it to a power source.

TRUE will not warranty any refrigerator/freezer that has been connected to an adapter plug.



USE OF EXTENSION CORDS

NEVER USE AN EXTENSION CORD! An extension cord is determined to be any component that adds length to the original OEM power cord when connecting it to a power source.

TRUE will not warranty any refrigerator/freezer that has been connected to an extension cord.



HOW TO CONNECT ELECTRICITY

- The ice maker should always be plugged into a dedicated electrical circuit. This provides the best performance and prevents building wiring circuits from being overloaded, which could cause a fire hazard from overheated wires.
- Before your new unit is connected to a power supply, check the incoming voltage with a voltmeter. If the recorded voltage is less than the rated voltage for operation (+/-5%) and amp rating, correct immediately. Refer to cabinet data plate for this voltage requirement.
- The electrical outlet must be within 36" (914.4 mm) of the center of the back wall of the ice maker's final location. Outlet must be flush with wall and comply with local electrical codes.
- The wall outlet and circuit should be checked by a licensed electrician to make sure the outlet is properly grounded.
- The power cord of this appliance is equipped with a 3-prong (grounding) plug which mates with a standard 3-prong (grounding) wall outlet to minimize the possibility of electric shock hazard from this appliance. A 115v AC, 60 Hz, 15 amp circuit breaker and electrical supply are required.
- If the outlet is a standard 2-prong outlet, it is your personal responsibility and obligation to have it replaced with the properly grounded wall outlet.
- **DO NOT**, under any circumstances, cut or remove the ground prong from the power cord. For personal safety, this appliance must be properly grounded.
- When moving the ice maker, for any reason, be careful not to roll over or damage the power cord.
- Repair or replace immediately all power cords that have become frayed or otherwise damaged. **DO NOT** use a power cord that shows cracks or abrasion damage along its length or at either end.
- If the supply power cord is damaged, it should be replaced with original equipment manufacturer (OEM) components. To avoid hazard this should be done by a licensed service provider.
- **NEVER** unplug your ice maker by pulling on the power cord. Always grip plug firmly and pull straight out from the outlet.

ELECTRICAL OUTLET LOCATION

To minimize the depth of the cutout opening, the electrical outlet must be positioned as shown below. Outlet must be flush with wall.

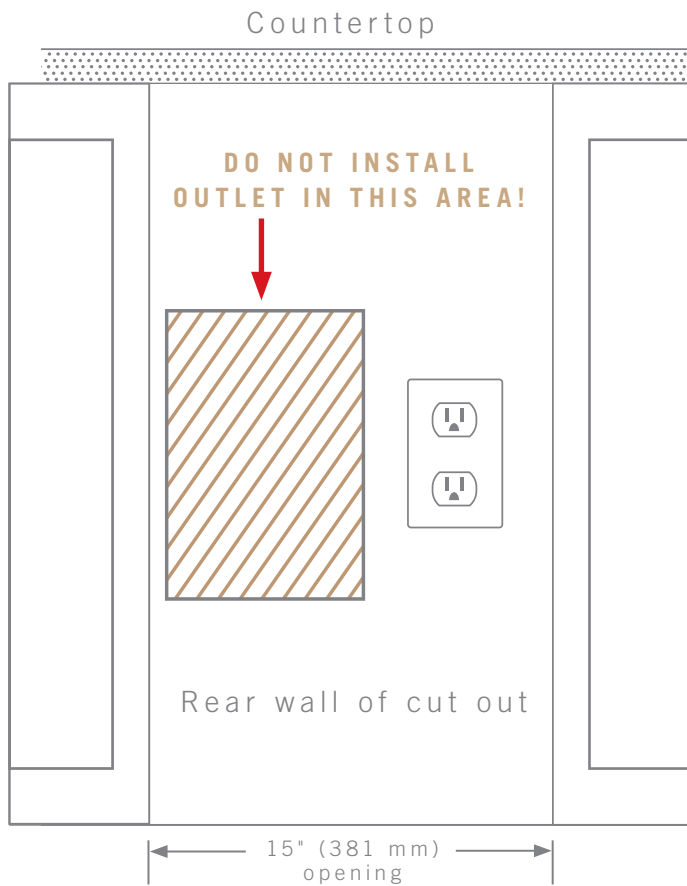

PRIOR TO INSTALLATION

PLUMBING REQUIREMENTS & INSTALLATION

	Water Temperature	Water Pressure
Minimum	40°F (4.4°C)	20 psig (1.4 bar)
Maximum	100°F (37.8°C)	80 psig (5.5 bar)

Plumbing Material	
Water Supply	<ul style="list-style-type: none"> • 1/4" O.D. copper • braided stainless steel • PEX tubing and compression fittings (1/4" lines and fittings not provided by TRUE)
Drain Connection	1/2" O.D. Female NPT Fitting (see fig. 1.)

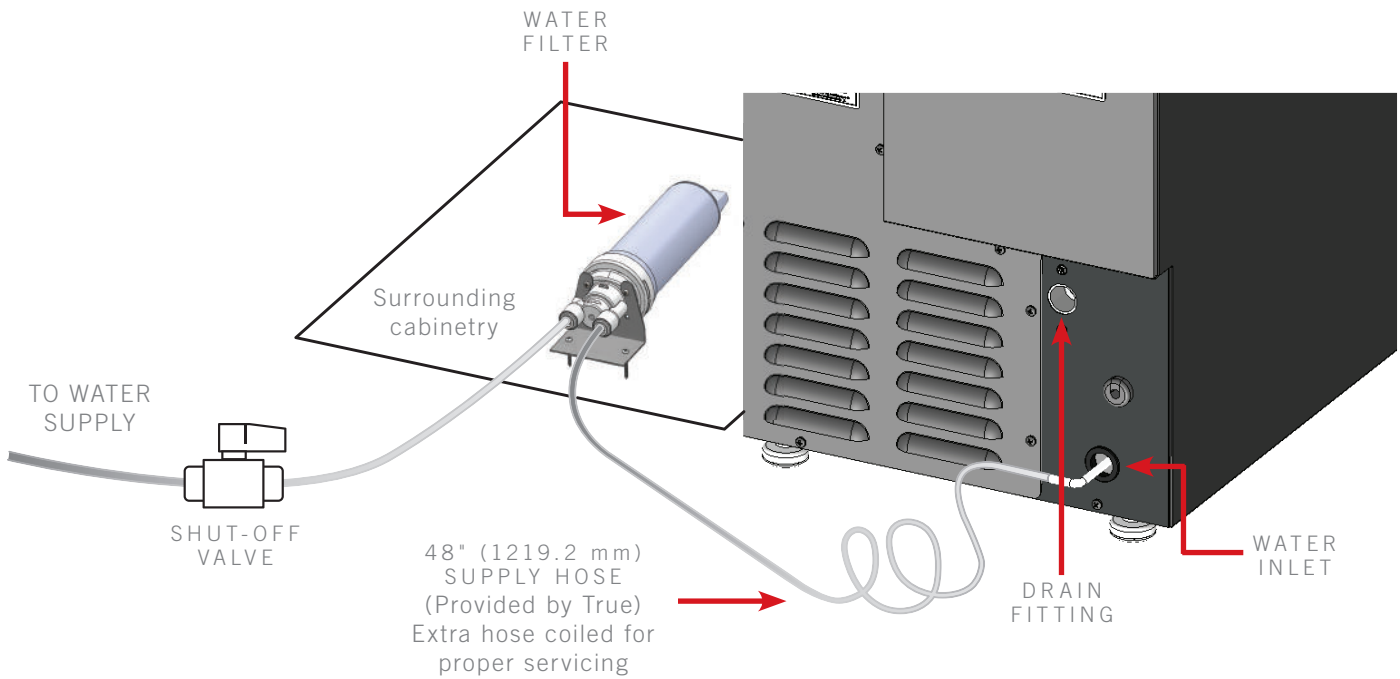

FIG. 1. Example of correct water supply and water filter installation.

WATER SUPPLY

- The ice maker comes with a 48" (1219.2 mm) of 1/4" O.D. PEX tubing for connecting the water filter to the unit. See fig. 1 for the ice machine's water inlet location.
- DO NOT connect the water supply directly to the icemaker. Connect the water supply to the water filter. Tubing for connecting water filter to water supply NOT provided by TRUE.
- **Failure to install the water filter will void the machine warranty.**
- The provided water filter must be installed within 30" (762 mm) of the ice machine's water inlet.
- Water pressure must be between 20-80 psig (1.4-5.5 bar). If the water pressure exceeds the maximum pressure, install a water pressure regulator.
- A reverse osmosis system can be used if there is constant water pressure of 20-80 psig (1.4-5.5 bar).
- Cold water supply required. Incoming water temperature must remain 40-100°F (4.4-7.8°C).
- Never connect to a hot water supply. Be sure all hot water restrictors installed for other equipment are working, such as check valves on sink faucets, dishwashers, etc.
- Water regulating valve recommended for pressures higher than 80 psig (5.5 bar). If so desired, installing a water hammer valve can reduce the noise and shock from the valve closing.
- Use tight-fitting, leak-proof permanent connections for the water supply. Soldered connections are always best. In the absence of soldering, use compression-type fittings for more reliability.
- While push fittings are acceptable, they are prone to leaks when installed incorrectly and/or not according to the manufacturer's specifications.
- TRUE recommends coiling extra length of supply hose behind the machine to allow proper servicing of the unit. See fig. 1.
- Connect the water supply line to the house supply with an easily accessible shut-off valve in your installation. See fig. 1.
- Insulate the supply line to prevent condensation.
- When switching to PEX, the tubing must be rated for 150 psi (10.3 bar) burst pressure minimum and 180°F (82.2°C).

WATER FILTER INSTALLATION

NOTE: FAILURE TO INSTALL THE WATER FILTER WILL VOID THE MACHINE WARRANTY.

The provided water filter removes any unpleasant taste and odor, as well as inhibiting scale.

- The ice maker comes with a 48" (1219.2 mm) of 1/4" O.D. PEX tubing for connecting the water filter to the unit.

NOTE: TUBING FOR CONNECTING WATER FILTER TO THE WATER SUPPLY NOT PROVIDED BY TRUE. SEE "WATER SUPPLY" (PAGE 37)

- **Install the water filter within 30" (762 mm) of the ice machine's water inlet.**
- Do not install the water filter behind the unit.
- The filter life expectancy is 12 months for low-scale water and 6 months for high-scale water.
- The ice maker monitors how long the filter has been in operation; the display will show **rtr** when the filter needs to be replaced. See Water Filter Replacement instructions on page [61](#).
- To order a replacement water filter, go to www.store.trueresidential.com/collections/maintenance-1 or contact our parts department at **844-849-6226** or TrueResidentialParts@TrueMfg.com.

CAUTION: DO NOT ALLOW THE ICE MACHINE TO BE EXPOSED TO TEMPERATURES BELOW 32°F (0°C) WITHOUT WINTERIZING THE MACHINE AS THIS WILL CAUSE ANY WATER IN THE MACHINE TO FREEZE. FAILURES CAUSED BY EXPOSURE TO FREEZING TEMPERATURES ARE NOT COVERED BY THE WARRANTY.

REQUIRED TOOLS

- (2) #8 Screws*
- Appropriate Bit Driver
- 1/8" Drill Bit (optional)
- Marking Utensil (optional)
- Drill

*Screw type varies by surface material.

PROCEDURE

1. Position the water filter head assembly. Then mark the bracket hole locations.
2. Carefully drill pilot holes in the marked locations.
3. Install the water filter head assembly.

NOTE: BE SURE THE BRACKET IS SECURELY FASTENED BEFORE INSTALLING THE FILTER.

4. Connect the water filter head to the icemaker water inlet (tubing provided by TRUE). See figs. 2 and 3.
5. Connect the water filter head to the water supply. (Tubing NOT provided by TRUE, see "Water Supply" on page [37](#)). See fig. 3.
6. Apply the provided lubricant to the water filter O-rings.
7. Align the filter with the filter head's teeth. See fig. 3.
8. Insert the water filter and rotate the water filter clockwise. See figs. 4 and 5.
9. Check all plumbing connections for leaks.

PRIOR TO INSTALLATION

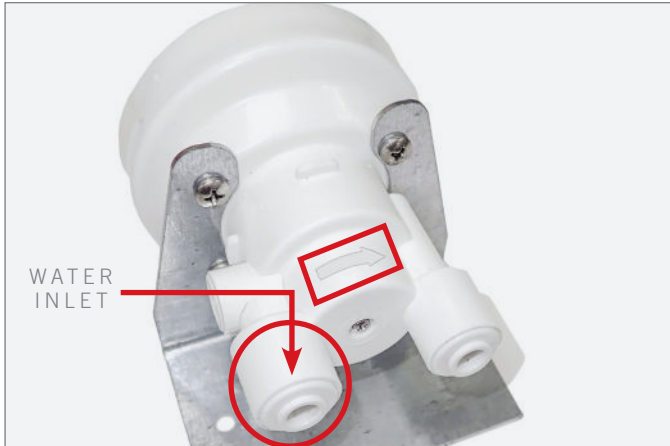

FIG. 1. The water inlet has the strainer and is behind the direction arrow.

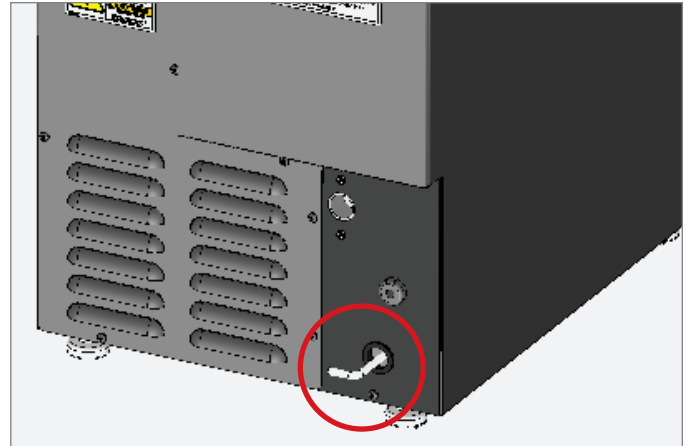

FIG. 2. Ice machine water inlet location.

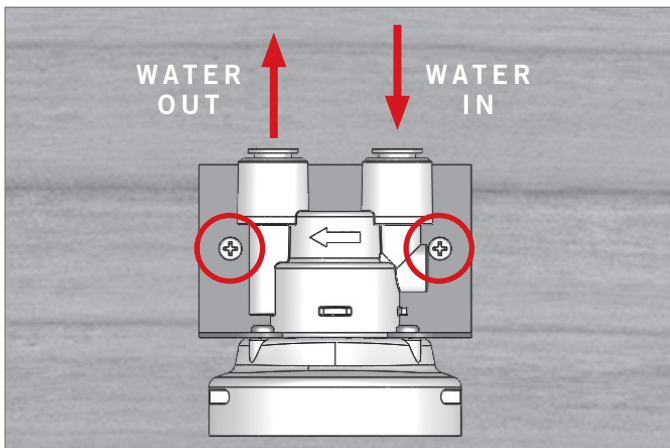

FIG. 3. Water filter head inlet, outlet, and bracket screw locations. Top-down view shown.

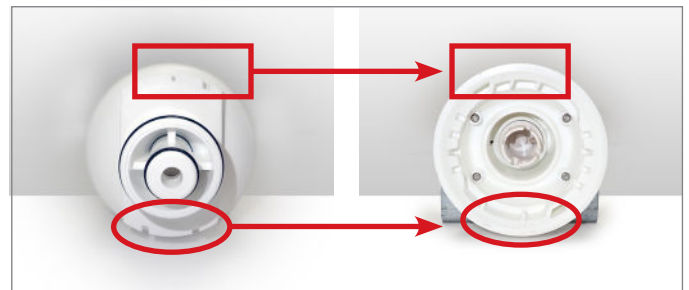

FIG. 4. Align the water filter's slots with the corresponding teeth in the filter head.

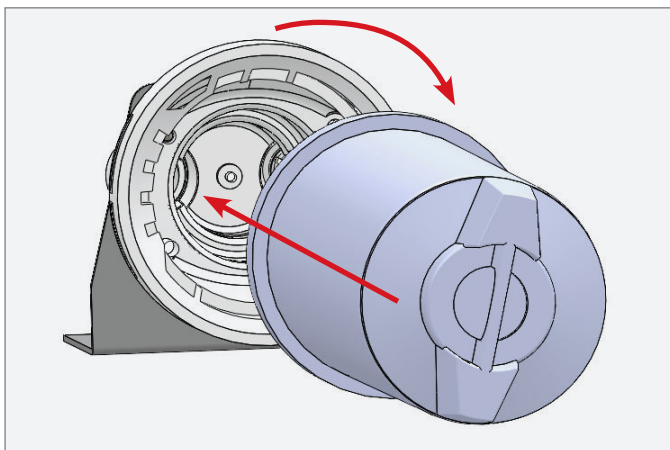

FIG. 5. Insert the water filter and rotate it clockwise.

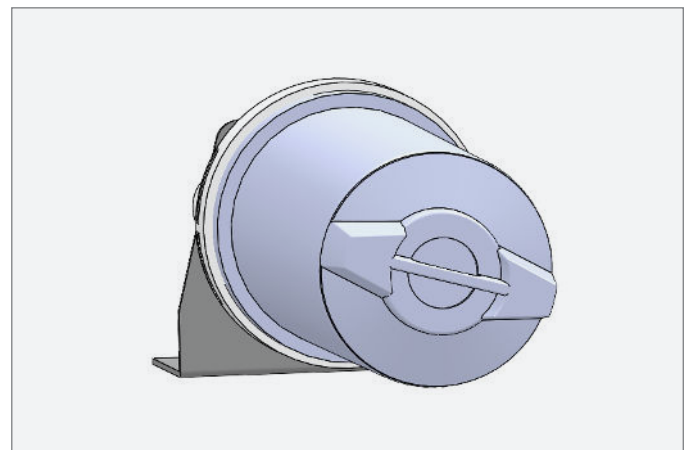

FIG. 6. Installed water filter.

DRAIN CONNECTION

The True Ice® machine has a built-in drain pump.

WARNING: PROPER INSTALLATION REQUIRES CONNECTION TO THE WATER SUPPLY AND A DRAIN. THESE CONNECTIONS ARE THE RESPONSIBILITIES OF THE INSTALLER. TRUE WILL NOT WARRANT LEAKS OR DAMAGE CAUSED BY IMPROPER INSTALLATION. IMPROPER CONNECTIONS CAN RESULT IN PERSONAL INJURY, PROPERTY DAMAGE AND IMPROPER OPERATION. THE ICE MACHINE MUST BE INSTALLED ACCORDING TO ALL APPLICABLE NATIONAL, STATE AND LOCAL CODES AND REGULATIONS.

DO NOT reduce drain connections any smaller than 3/8" O.D.

- 84" (2,133.6 mm) Clear PVC drain hose, 1/2" male NPT connector, and 3/8" hose clamp provided by True
- Using hose larger than 1/2" O.D. may require a larger pump. A check valve may be required to prevent excessive cycling of the drain pump.
- Be sure to use the correct O.D. hose for your vertical rise to ensure the proper flowrate and prevent drain time alarms. For more information, see "Drain Time Alarm" (page 54).
- If the installation requires a **vertical rise greater than 84" (2,133.6 mm)** include an external drain pump to cover the additional required pumping height. Connect the drain tube outlet from the ice maker to the external drain pump inlet. **Do not remove the internal drain pump provided with the ice maker.** Altering the internal components in any way will void the warranty.
- **DO NOT USE HOSE SMALLER THAN 3/8" O.D.**
- The floor drain must be large enough to accommodate additional drainage.
- The drain pump discharge line must terminate at an open site drain.
- Be sure to thoroughly inspect all connections after installation to ensure there are no leaks. Use of thread sealant recommended.

PROCEDURE

1. Thread the 1/2" NPT connector into the drain fitting. See fig. 1.

NOTE: THREAD SEALANT REQUIRED AND TO BE SUPPLIED BY INSTALLER.



NOTICE: DO NOT OVERTIGHTEN THE NPT CONNECTOR!

DO NOT TORQUE THE CONNECTOR MORE THAN 50 IN-LB (5.65 NM).

THIS MAY CAUSE THE FITTING TO CRACK. CHECK THE DRAIN FITTING FOR LEAKS BEFORE COMPLETING THE INSTALLATION.

2. With the clamp on the hose, connect the clear drain hose to the barbed fitting. See fig. 1.
3. Tighten the hose clamp.

NOTE: VERIFY THE ICE MAKER DRAINS THROUGH TWO CYCLES WITHOUT ANY DRAIN ALARM DURING INSTALLATION.

For more information, see "Drain Time Alarm" (page 54).

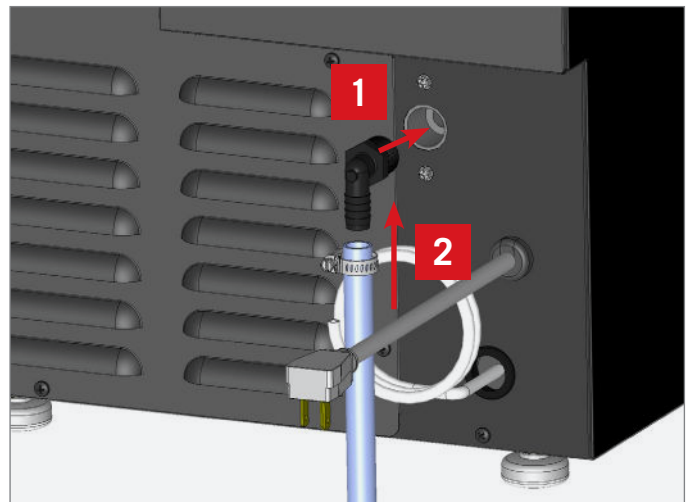

FIG. 1. Be sure to tightly clamp the drain line into the barbed fitting. Thread sealant required.

CHECK VALVE INSTALLATION

1. Locate the provided check valve kit. See fig. 2.
2. With tubing cutters, cut the drain line near the connection point. See fig. 3.
3. With the water flow arrow (see fig. 4) pointing away from the ice machine, connect the cut drain line to the check valve. See fig. 5. Use the provided adapters and clamps as needed.
4. Check the drain system for leaks.



FIG. 2. Check valve kit shipped inside the ice machine.



FIG. 3. Cut the drain line with tubing cutters.

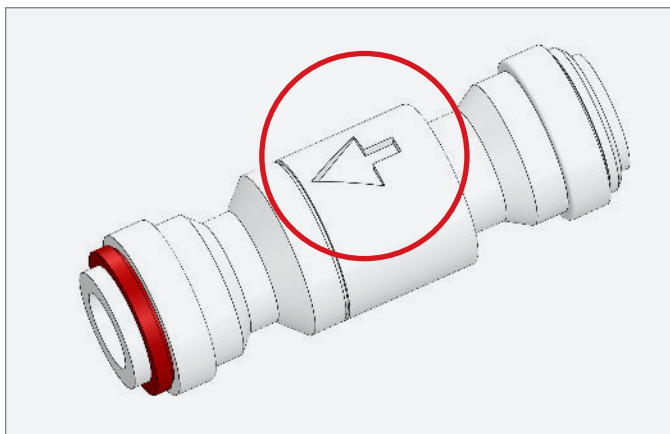

FIG. 4. Water flow arrow on the check valve.



FIG. 5. Installed check valve.

PRIOR TO INSTALLATION

PUMP HEIGHTS

Do NOT exceed the Maximum Vertical Rise. See table on right, diagrams below.

	Maximum Vertical Rise	Maximum Run
3/8" O.D. Hose (provided by TRUE)	84" (2,133.6 mm)	100' (30.84 m)
1/2" O.D. Hose	48" (1,219.2 mm)	100' (30.84 m)
Hose larger than 1/2" O.D. may require an external pump.		
Vertical rise higher than 84" will require external pump.		

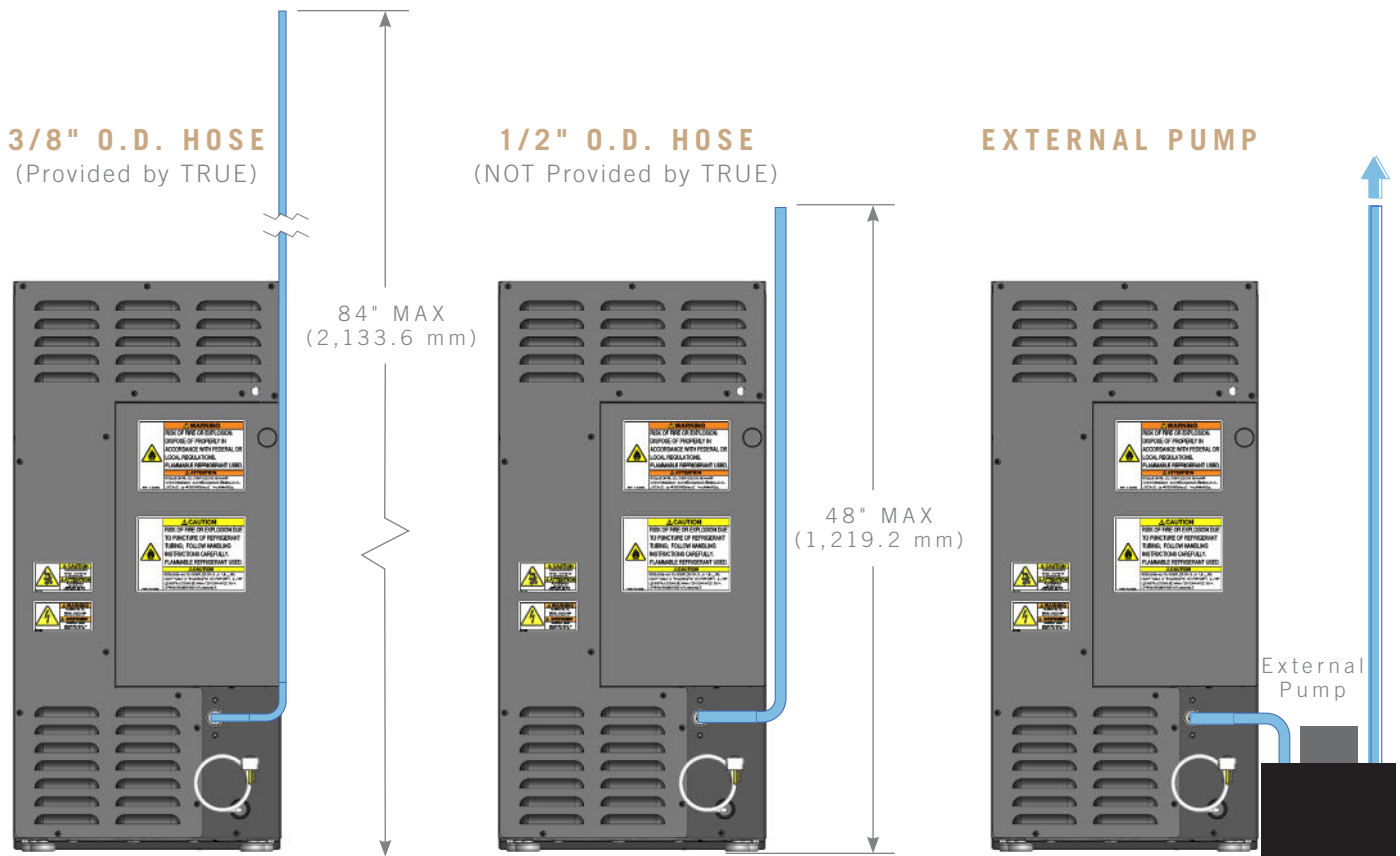

INSTALLATION

UNCRATING

LEVELING LEGS

LEVELING

KICKPLATE INSTALLATION

WATER FILTER INSTALLATION



LUXURY REFRIGERATION WITH COMMERCIAL DNA

UNCRATING

REQUIRED TOOLS

- Cutting Tool
- Hammer
- Crowbar
- Phillips Screwdriver
- Floor Protector

PROCEDURE

The following procedure is recommended for uncrating the unit:

1. Remove the outer packaging (cardboard and clear plastic). See fig. 1.
2. Inspect the unit for concealed damage. **Immediately file a claim with the freight carrier if there is damage.**
3. Cut the plastic band and remove the foam block. See fig. 2.

NOTE: MOVE THE UNIT AS CLOSE AS POSSIBLE TO ITS FINAL LOCATION BEFORE REMOVING THE SKID.

4. Position the floor protector next to the skid.
5. Carefully lift the unit off the skid and place the unit on the floor protector. See fig. 3.
6. Remove the interior packaging.



FIG. 1. Pull the staples from the skid.

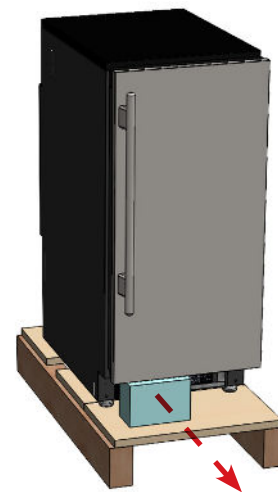

FIG. 2. Remove the foam block after moving the unit as close as possible to the final installation location.

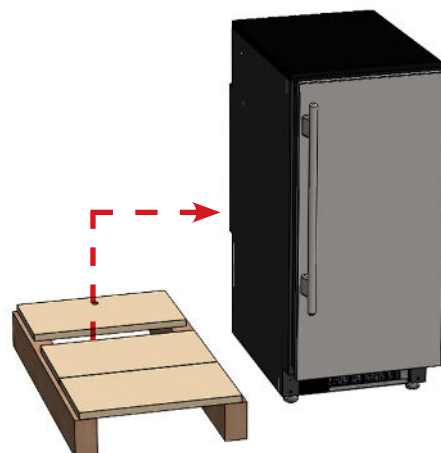

FIG. 3. Carefully move the unit off the skid.

LEVELING LEGS

PROCEDURE

With access to the bottom of the cabinet, turn the leveling legs to adjust the level as needed.

See figs. 1 and 2.

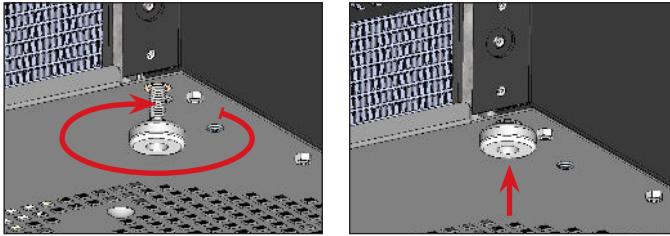

FIG. 1. Turn the leveling legs clockwise to lower the unit.

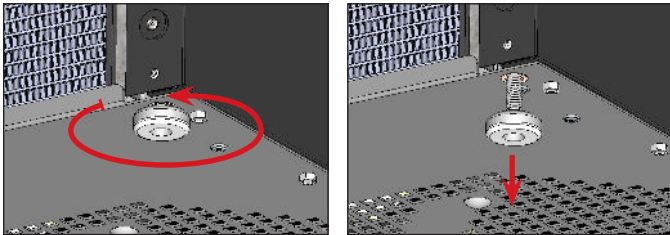

FIG. 2. Turn the leveling legs counterclockwise to raise the unit.

2-1/2" LEVELING LEGS

2-1/2" (64 mm) leveling legs raise the minimum height of the unit to 33-3/4" (857.25 mm). The leveling legs are adjustable up to 1" (25.4 mm), raising the maximum height of the unit to 34-3/4" (882.7 mm). If so desired, you can order a taller grill to hide the gap caused by the 2-1/2" leveling legs. Please contact our parts department at **844-849-6226** or TrueResidentialParts@TrueMfg.com.

PROCEDURE

1. Access the bottom of the cabinet.
2. Remove the existing standard leveling legs. See fig. 3.
3. Thread the new leveling legs into the bottom of the cabinet. See fig. 4.
4. Verify the level of the cabinet. If the cabinet is not level, gently lift and support the low end of the cabinet. Then, adjust the bottom stem of the leveling leg to level and support the cabinet. See fig. 5.

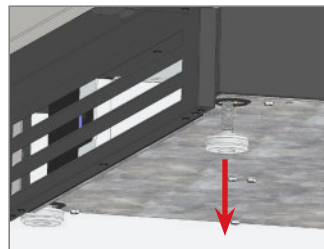

FIG. 3. Remove the existing leveling legs.

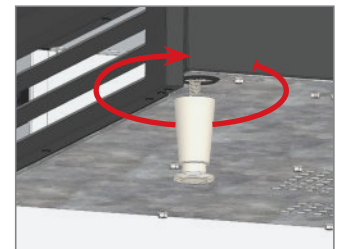

FIG. 4. Screw in the leveling legs.



FIG. 5. Turn the bottom stem to level the cabinet.

INSTALLATION

LEVELING

Proper leveling of your ice maker is critical to operating success. Leveling effects drainage and door operation.

PROCEDURE

1. Set the unit in its final location. Be sure there is adequate ventilation in your room.
2. Verify the unit's level. On the unit's top, check the level front-to-back and side-to-side. See fig. 1.
3. Turn the leveling legs as needed to adjust the level. See "Leveling Legs" (page [45](#)).

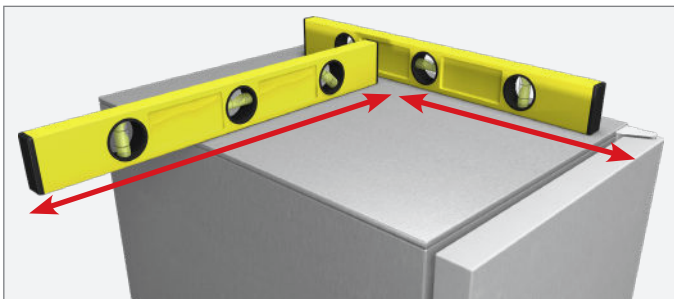

FIG. 1. Check the level from the top of the unit.

KICKPLATE INSTALLATION

The kickplate is shipped unattached to the unit to allow easy access for levelling. The kickplate attaches to the unit with magnets at the bottom of the unit.

PROCEDURE

1. After leveling the unit, position the kickplate below the door. See figs. 1 and 2.
2. Verify the kickplate is correctly aligned. Adjust as needed.

REMOVAL

Pull the kickplate away from the unit.

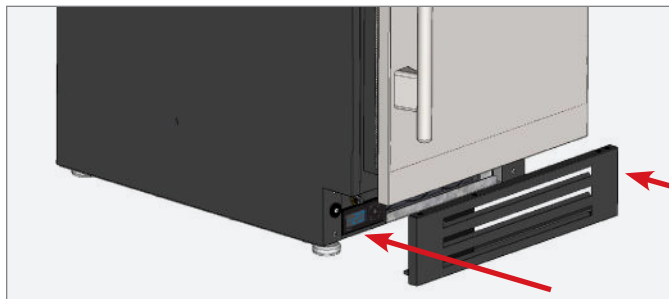

FIG. 1. Attach the kickplate to the magnets below the door.

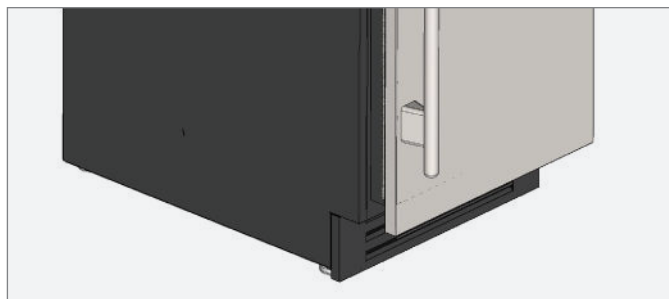

FIG. 2. Adjust the kickplate as needed.

ICE SCOOP

90° DOORSTOP INSTALLATION (OPTIONAL ACCESSORY)



LUXURY REFRIGERATION WITH COMMERCIAL DNA

ICE SCOOP

For easy storage, position the ice scoop on the door's interior. See fig. 1.

PROCEDURE

1. Orient the door as desired. See "Reversing Door". (page 74).
2. Locate the ice scoop in the interior packaging.
3. Position the ice scoop on the door's interior. See fig. 1.

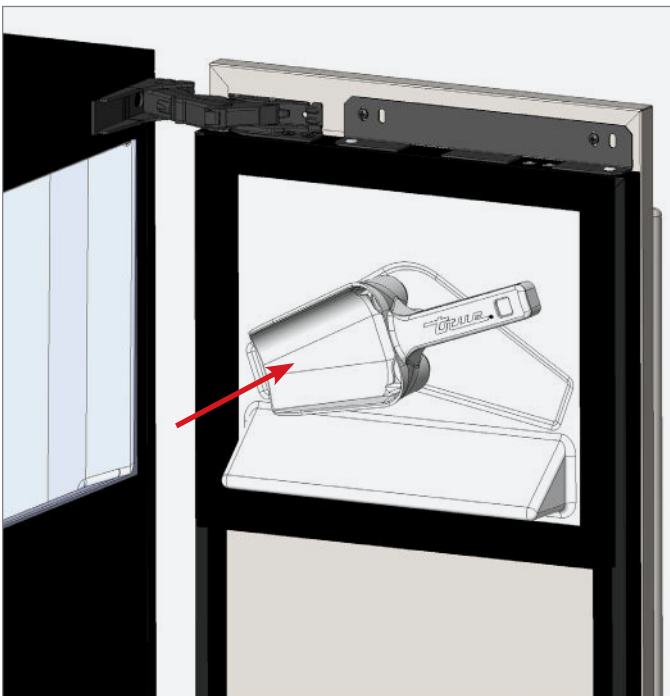

FIG. 1. Attach the ice scoop to the door.

90° DOORSTOP INSTALLATION (OPTIONAL ACCESSORY)

The doorstop restricts the door from opening past approximately 90° to prevent damage to surrounding cabinets.

NOTE: BE SURE TO PUT A DOORSTOP PIN IN BOTH THE TOP AND BOTTOM HINGES. SEE FIGS. 1 AND 2.

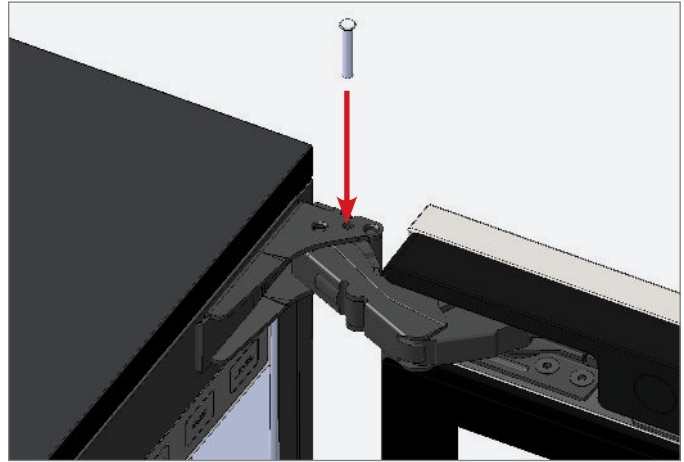

FIG. 1. Drop the doorstop pin into the articulated hinge.

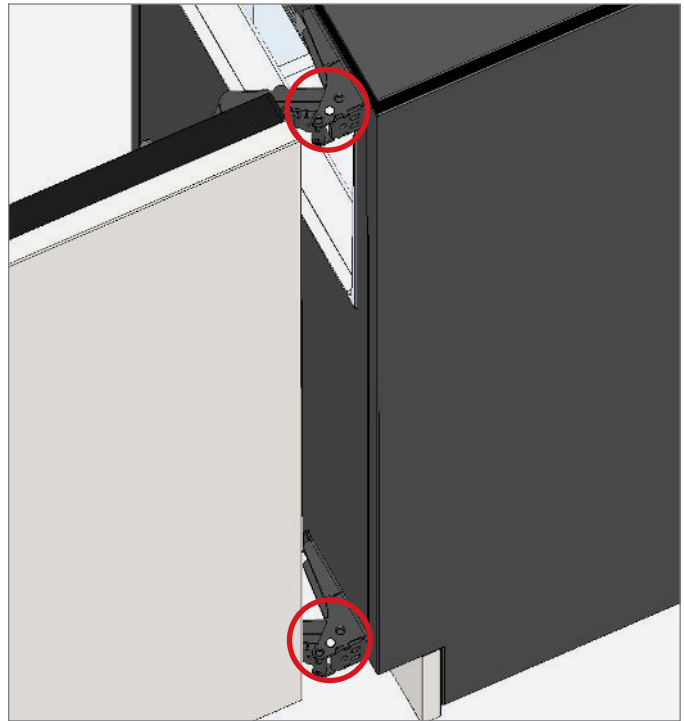

FIG. 2. Install a doorstop pin in both hinges.

BEFORE OPERATING

BREAKER RESET

POWER SEQUENCE

ICE MAKING SEQUENCE

ELECTRONIC CONTROL OPERATION



LUXURY REFRIGERATION WITH COMMERCIAL DNA

BEFORE OPERATING

Before running the unit, verify the water shutters and pump cap are correctly installed. Failure to do so can cause incorrect operation. See "Interior Components" on page [68](#).

To ensure ice quality, please clean and sanitize this machine prior to first use. See "Descaling & Sanitizing" (page [66](#)). To ensure proper operation, follow the installation checklist at the front of this manual.

NOTE: COSTS ASSOCIATED WITH ADJUSTMENTS, CLEANING AND SANITIZING PROCEDURES IN THIS GUIDE ARE NOT COVERED BY THE WARRANTY.



WARNING! DO NOT USE THE ICE MACHINE TO STORE ANYTHING OTHER THAN ICE.



WARNING! DO NOT OPERATE EQUIPMENT THAT HAS BEEN MISUSED, NEGLECTED, DAMAGED, ALTERED OR MODIFIED IN ANY

WAY.

BREAKER RESET

The breaker switch is located behind the kickplate (see fig. 1). If the unit trips, press the breaker to reset the switch.

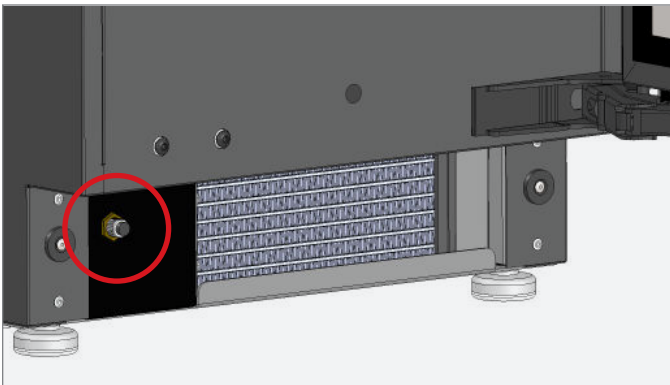



FIG. 1. Breaker switch location.

POWER SEQUENCE

- Press the power button  once to begin ice making operation. Press the button a second time to turn the ice machine off.
- When unit is plugged in, the control board goes through a sequence of checks to verify all sensors are working properly.
- The drain system is energized when power is supplied to the unit. It automatically turns on when it senses water in the drain tube.
- Display will show **oFF** until the power button is pressed.
- If the unit powers the drain pump but the drain remains clogged for five minutes, the display will show **drn** and cut power to the unit.
- If unit is too cold / too hot, or if the temperature probe is unplugged / failed, the unit shuts down and displays an error message.

ICE MAKING SEQUENCE

Your TRUE Ice® machine will produce one batch of ice (24 cubes) approximately every 20 minutes.

The following steps occur during ice making —

INITIAL FILL / INITIAL HARVEST

The ice machine always begins in Fill mode.

During Fill or Harvest modes —

- The display will read **FiL** (Fill mode) or **hAr** (Harvest mode).
- The reservoir fills with water (for 2–3 minutes)
- Excess / residual water drains.
- Any residual ice cubes from a previous cycle are melted free from the evaporator by warming the evaporator with a warm refrigerant (Harvest mode).

ICE MAKING

When making ice —

- The display will read **ICE**
- Water sprays into the inverted ice cups as the evaporator cools, forming ultra-clear ice cubes in each cup
- The compressor, condenser fan motor, and water pump operate.
- As ice is produced on the evaporator, the reservoir's water level will lower.
- Adjusting the ice cube size alters the water level needed for completing the cycle.
- The ice making cycle ends when
- The reservoir's water level has dropped to a sufficient level based on the ice cube size setting
OR
- When the t1 evaporator probe detects the minimum temperature threshold.

ICE HARVEST

When harvesting ice —

- The display will read **hAr**
- The compressor remains on, but the condenser fan motor and pump turn off. The hot gas bypass and water valves open.
- As the evaporator warms, ice cubes begin to fall into the ice bin.
- The reservoir refills with water and overflows to flush impurities down to the drain pump.
- The harvest cycle ends when the evaporator reaches 47°F (8.3°C) and then a completion timer expires.
- All 24 ice cubes should fall into the ice storage bin before the next ice making cycle begins.

FULL BIN

When the ice bin is full —

- The display will read **FUL**
- The ice machine shuts off automatically when the ice level sensor determines the amount of ice has reached the set level.
- The condenser fan will turn on in reverse to clean the condenser; this removes any built-up dust or debris, which prolongs the time needed between full condenser coil cleanings.
- The drain pump will periodically run to remove any residual water in the bin from melted ice cubes.
- The ice machine turns back on when the ice level sensor determines the amount of ice has decreased to below the set level.

CABINET OPERATION

ELECTRONIC CONTROL OPERATION

ELECTRONIC CONTROL LEGEND

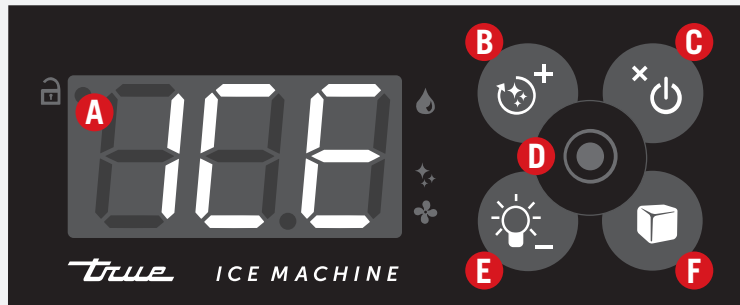

A. DISPLAY

B. INITIATE AUTOMATIC CLEAN;
SCROLL UP (IN MENU MODE)

C. TOGGLES POWER/STANDBY;
BACK/RETURN

D. OKAY/ENTER; UNLOCK

E. TOGGLES LIGHT/ CHANGE BIN
LIGHT COLORS; SCROLL DOWN
(IN MENU MODE)

F. ADJUST CUBE SIZE



WATER FILTER REMINDER



CLEANING REMINDER



AIR FILTER REMINDER

CABINET OPERATION

ELECTRONIC DISPLAY CODES

Display	Definition	Detailed Description
	Clean cycle reminder	In Menu Mode: view the number days elapsed since the automatic clean cycle was performed
	Drain pump failure	Clogged or kinked drain line. Drain was not able to clear within 5 minutes of running.
	Thermistor 1 Failure	Thermistor 1 is located on the evaporator outlet tube and is used for terminating the harvest. E1 means the probe has a bad or loose connection.
	Thermistor 2 Failure	Thermistor 2 is located on the condenser outlet tube and is used for fan cycling. E2 means the probe has a bad or loose connection.
	Fill mode	Water fills the reservoir for 2-3 minutes
	Condenser coil cleaning reminder	In Menu Mode: view the number of days elapsed since the last condenser coil cleaning.
	Freeze time	In Menu Mode: view the most recent freeze times in minutes. View history of five previous cycles: -1 (most recent), -2, -3, -4, -5
	Ice storage bin is full	Ice has reached the full level and the unit is in standby.
	Water level sensor	In Menu Mode: h1 is the water level reading inside the sump tank read in mm of H ₂ O.
	Ice level sensor	In Menu Mode: h2 is the ice level reading inside the ice storage bin in cm. Full = 35.0 and Empty = 55.0
	Harvesting ice	Ice cubes drop in the storage bin and water fills the reservoir for the next batch of ice.
	Harvest time	In Menu Mode: view the most recent harvest times in minutes. View history of five previous cycles -1 (most recent), -2, -3, -4, -5
	Making ice	Circulation pump is running, machine sprays water into the molds to make cubes.
	High Pressure sensor (Optional)	In Menu Mode: P1 is the high side pressure transducer taken at the compressor discharge read in PSI (lb/in ²)
	Low Pressure sensor (Optional)	In Menu Mode: P2 is the low side pressure transducer taken at the compressor suction read in PSI (lb/in ²)
	Water filter reminder	In Menu Mode: view the number of days elapsed since the last water filter replacement
	Evaporator temperature	In Menu Mode: t1 is the evaporator outlet temperature read in degrees Fahrenheit
	Condenser temperature	In Menu Mode: t2 is the condenser outlet temperature read in degrees Fahrenheit

DRAIN TIME ALARM

If the drain does not clear within 5 minutes of running, the display will show **drn** to signal a clogged / kinked drain line or a drain pump failure. The control automatically shut off the water supply.

If a clogged drain clears, the display will show **drn** and **oFF**.



NOTICE! ADHERE TO LOCAL AND STATE PLUMBING CODES. DO NOT EXCEED THE MAXIMUM PLUMBING HEIGHTS FOR THE GIVEN SETUP. SEE "DRAIN CONNECTION" (PAGE 40). THE DRAIN ALARM IS INITIATED BY THE CONTROL BOARD IN THE EVENT OF IMPROPER DRAINAGE.

NOTE: VERIFY THE ICE MAKER DRAINS THROUGH TWO CYCLES WITHOUT ANY ALARM DURING INSTALLATION.

MAINTENANCE REMINDERS

Your ice machine will remind you to clean, when to perform the automatic clean, when to clean condenser coil, and when to replace your water filter.

 Water Filter reminder

 Cleaning reminder

 Air Filter reminder

CONDENSER CLEANING REMINDER

Days elapsed since last condenser coil cleaning.

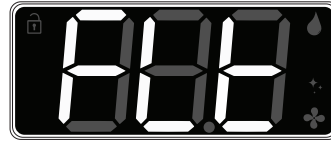

WATER FILTER REMINDER

Total time elapsed (shown in days) of water running through the filter since the last water filter replacement.

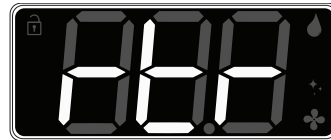

AUTOMATIC CLEANING REMINDER

Days elapsed since last performed automatic cleaning.



RESET REMINDERS

Press both the light  and clean  buttons.

NOTE: RESETTING THE REMINDERS RESETS BOTH THE CONDENSER CLEANING AND THE WATER FILTER REPLACEMENT REMINDERS.

NOTE: THE AUTOMATIC CLEAN REMINDER CAN ONLY BE RESET BY COMPLETING THE AUTOMATIC CLEANING CYCLE.

BIN LIGHT



Press the light button  to control the bin light.

- Press the light button repeatedly to cycle through the 14 preset designer light colors
- Press and hold the light button for 5 seconds to toggle the bin light on or off.

ADJUST CUBE SIZE

The ice cube size is easily adjustable to meet your usage.



The available cube sizes range from -6 (smallest) to +6 (largest). The default is 0.

To adjust the cube size, press the size button  until the display shows the desired setting.

ADJUST FOR WATER QUALITY

The water quality setting allows your ice machine to easily accommodate different levels of water quality / hardness / scale. The available settings range from 0 (soft water / low scale) to 5 (hard water / high scale). The default setting is 0. Please see fig. 1.

If you are unsure of your water quality, check your water with a water quality test kit (not provided by TRUE).

To adjust for water quality, press both the light  and size  buttons.

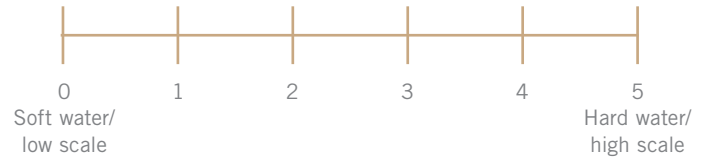















FIG. 1. Water quality setting range.

CABINET OPERATION















COMMANDS AND KEY COMBINATIONS

See the table below for commands and their corresponding key combinations.

Command	Key Combination	Display Code	Detailed Description
Unlock	Press the center button 2 times 	n/a	Unlocks control; control will relock after 60 seconds of inactivity
Power unit on / off	Press and hold the power button for 3 seconds 		Turns the unit on and off.
Change light color	Press the light button 		Switch between the 14 LED colors.
Adjust cube size	Press the size button until the display shows the desired setting 		Adjusts cube size in increments from 1 to 6 for larger cubes, then -6 to -1 for smaller cubes. Ice Size default is 0.
Clean Mode	Press and hold the clean button for 3 seconds 		Press and hold Clean for 3 seconds to begin (or end) the automatic cycle. Follow the prompts to select the settings and start the cycle.
Add cleaning chemicals	After adding cleaning chemicals, press the clean button 		In Clean Mode, the "Add" notification notifies when to add cleaners to the sump tank. Once complete, push any button to continue the automatic cycle.
Adjust for water quality	Press both the light and the size buttons 		Soft water / low scale setting is 0. Hard water / high scale setting is 5. Adjusting the value higher flushes more water between cycles, resulting in clearer ice cubes.

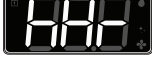
COMMANDS AND KEY COMBINATIONS

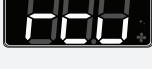
See the table below for commands and their corresponding key combinations.

Command	Key Combination	Display Code	Detailed Description
Reset maintenance reminders	Press both the light and the clean buttons.  + 		Resets the condenser cleaning and water filter replacement reminders. Both are reset when pressed. See "Maintenance Reminders" (page 54).
Circulate pump motor	Press the clean button 2 times. 		In Standby: Circulates the Pump motor (on / off).
Initiate manual drain pump operation	Press and hold both the clean and size buttons.  + 	n/a	Bypasses the background operations and runs the drain pump only while buttons are held.
Initiate manual fill	Press the clean button 3 times. 		In Standby: Starts a Manual Fill Routine.
Initiate manual harvest	Press and hold the power and the clean buttons for 3 seconds.  + 		In Standby of Freeze: Starts a Manual Harvest Cycle.
Initiate reverse condenser cleaning	Press and hold the power and the size buttons for 3 seconds.  + 		In Standby: Starts a Reverse Condenser Cleaning.
Clear the alarm history	Press the power button 2 times. 	n/a	Removes any alarms from the machine's memory.

GENERAL MAINTENANCE

WATER FILTER REPLACEMENT

CONDENSER COIL CLEANING

APPLIANCE CARE AND CLEANING

DESCALING & SANITIZING

INTERIOR COMPONENTS

WINTERIZING



LUXURY REFRIGERATION WITH COMMERCIAL DNA

GENERAL MAINTENANCE

You are responsible for maintaining the ice machine in accordance with the instructions in this manual. Maintenance procedures are not covered by warranty.

True recommends performing the following maintenance procedures a minimum of once every six months to ensure reliable, trouble-free operation.



WARNING! IF YOU DO NOT UNDERSTAND THE NECESSARY PROCEDURES OR SAFETY PRECAUTIONS, CALL YOUR LOCAL TRUE SERVICE REPRESENTATIVE TO PERFORM MAINTENANCE PROCEDURES FOR YOU.



CAUTION! TAKE CARE DURING OPERATION, MAINTENANCE, OR REPAIRS TO AVOID CUTS OR PINCHING FROM ANY CABINET PART/COMPONENT.

EXTERIOR CLEANING

Clean the exterior as needed. Follow Stainless Steel Cleaning and Restoration (page 64) to ensure your machine always looks like new.

DESCALING & SANITIZING

Descale and sanitize every 6 months. See "Descaling & Sanitizing" (page 66).

WATER FILTER REPLACEMENT

Replace the water filter at least once every 12 months. More frequent replacement may be required based on your water quality. See "Water Filter Replacement" (page 61).

CONDENSER CLEANING

For optimum operation, clean your condenser coil every 6 months. See "Condenser Coil Cleaning" (page 62).

Maintenance	Weekly	Semi-Annual	Annual	After Prolonged Shutdown	At Start-Up
Clean Cabinet Exterior	X			X	X
Sanitize Ice Machine		X	X	X	X
Descale Ice Machine		X	X	X	X
Clean Condenser Coil		X	X	X	
Change the Water Filter		X	X	X	
Check Ice Quality	X	X	X	X	X

WATER FILTER REPLACEMENT

To order a replacement water filter, go to store.trueresidential.com/collections/maintenance-1/products/full-size-models-replacement-water-filter or contact our parts department at **844-849-6226** or TrueResidentialParts@TrueMfg.com.

NOTE: BE SURE TO RESET THE WATER FILTER REPLACEMENT REMINDER AFTER REPLACING THE WATER FILTER. SEE "MAINTENANCE REMINDERS" (PAGE 54).



NOTICE! TRUE RECOMMENDS TURNING OFF THE WATER SUPPLY BEFORE REPLACING THE WATER FILTER TO PREVENT WATER FILTER DAMAGE OR LEAKS.



NOTICE! DO NOT INSTALL THE WATER FILTER WHILE THE WATER SUPPLY IS PRESSURIZED. ALWAYS RELIEVE THE WATER PRESSURE BEFORE CHANGING THE FILTER.

PROCEDURE

1. Relieve the water pressure.
2. Rotate the water filter counterclockwise and pull the filter from the unit. See fig. 1.
3. Apply the provided lubricant to the replacement water filter o-rings.
4. Insert the replacement water filter and rotate the filter clockwise. See fig. 2.

NOTE: BE SURE TO RESET THE WATER FILTER REPLACEMENT REMINDER AFTER REPLACING THE WATER FILTER. SEE "MAINTENANCE REMINDERS" (PAGE 54).

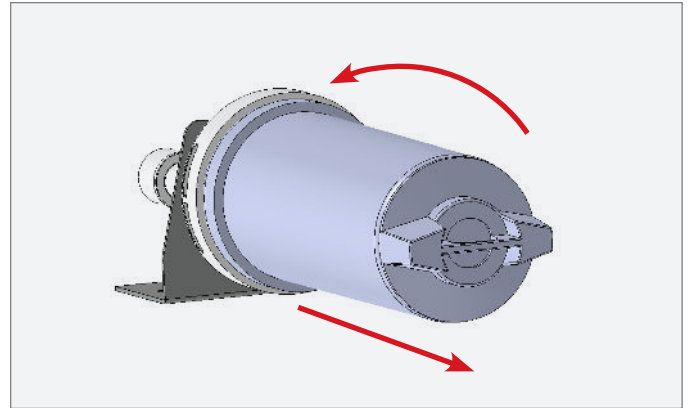

FIG. 1. Rotate the existing water filter counterclockwise and pull.

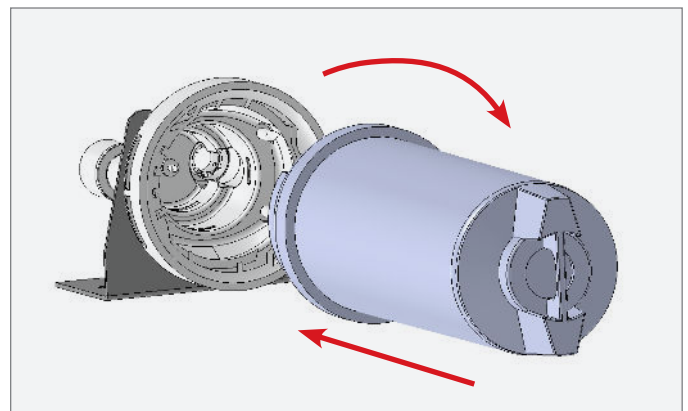

FIG. 2. Insert the replacement water filter and rotate it clockwise.

CONDENSER COIL CLEANING

Keeping the condenser coil clean minimizes required servicing and lowers electrical cost. Warranty does not cover cleaning the condenser coil.

NOTE: BE SURE TO RESET THE CONDENSER COIL CLEANING REMINDER AFTER CLEANING THE CONDENSER COIL. SEE "MAINTENANCE REMINDERS" (PAGE 54).



WARNING – Electrical shock or burn hazard. Unplug the unit or turn off the power supply before proceeding. **DO NOT** clean appliance with a pressure washer or hose.

ATTENTION – Risque d'électrocution ou de brûlure. Débranchez l'appareil ou coupez l'alimentation électrique avant de continuer. Ne nettoyez pas l'appareil avec un nettoyeur haute pression ou un tuyau.



CAUTION – Risk of eye injury from debris. Eye protection is recommended.

ATTENTION – Les ailettes sont coupantes. Soyez prudent pour éviter les lésions oculaires. Une protection des yeux est recommandée.



CAUTION – Coil fins are sharp. Gloves are recommended.

ATTENTION – Les ailettes de la bobine sont tranchantes. Les gants sont recommandés.

REQUIRED TOOLS

Required tools include (but may not be limited to) the following.

- Gloves
- Eye Protection
- Stiff Bristle Brush
- Vacuum Cleaner
- Flashlight
- Tank of Compressed Air

PROCEDURE

1. Remove the kickplate. See fig. 1.
2. With a stiff bristle brush, carefully clean accumulated dirt from the front coil fins.
3. With the dirt removed from the surface of the coil, use a flashlight to verify you can see through the coil and observe the condenser fan blade spinning. See fig. 3.
4. If the view is clear, reinstall the kickplate, restore power, and verify correct operation.
5. If the view is not clear, gently blow compressed air or CO₂ through the coil until it is clean.
6. Carefully vacuum any dirt around the condensing unit area.
7. Reinstall the kickplate, restore power, and verify correct operation.

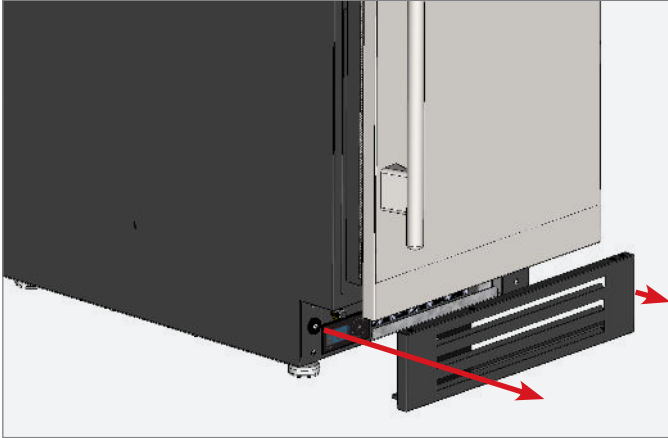

FIG. 1. Pull the kickplate off the magnets.

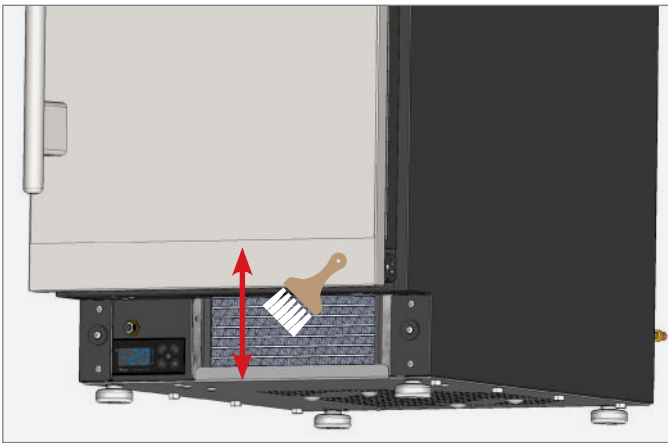

FIG. 2. Never brush across the coil fins.



FIG. 3. Verify all blockages have been removed.

APPLIANCE CARE & CLEANING



CAUTION: DO NOT USE ANY STEEL WOOL, ABRASIVE OR CHLORINE BASED PRODUCTS TO CLEAN STAINLESS STEEL SURFACES.

STAINLESS STEEL OPPONENTS

There are three basic things which can break down your stainless steel's passivity layer and allow corrosion to form.

- Scratches from wire brushes, scrapers, and steel pads are just a few examples of items that can be abrasive to stainless steel's surface.
- Deposits left on your stainless steel can leave spots. You may have hard or soft water depending on what part of the country you live in. Hard water can leave spots. Hard water that is heated can leave deposits if left to sit too long. These deposits can cause the passive layer to break down and rust your stainless steel. All deposits left from food prep or service should be removed as soon as possible.
- Chlorides are present in table salt, food, and water. Household and industrial cleaners are the worst type of chlorides to use.

STAINLESS STEEL CLEANING AND RESTORATION

Stainless steel cleaners must be free of phosphates, chlorine, chloride, and ammonia.

TRUE offers environmentally-friendly cleaner and polish through our True Store at <https://store.trueresidential.com/products/stainless-steel-clean-polish-kit>

CUSTOM PAINTED APPLIANCES AND HARDWARE

For painted doors and other surfaces, use a mild solution of soap and water with a soft microfiber cloth.

APPLIANCE CARE & CLEANING

8 TIPS TO HELP PREVENT RUST ON STAINLESS STEEL

- **Maintain the Cleanliness of Your Equipment –** Avoid build-up of hard stains by cleaning frequently. Use cleaners at the recommended strength (alkaline chlorinated or non-chloride).
- **Use the Correct Cleaning Tools –** Use non-abrasive tools when cleaning your stainless steel products. The stainless steel's passive layer will not be harmed by soft cloths and plastic scouring pads.
- **Clean Along Polishing Lines –** Polishing lines ("grain") are visible on some stainless steels. Always scrub parallel to polishing lines when visible. Use a plastic scouring pad or soft cloth when you cannot see the grain.
- **Use Alkaline, Alkaline-Chlorinated or Non-Chloride Cleaners –** While many traditional cleaners are loaded with chlorides, the industry is providing an ever increasing choice of non-chloride cleaners. If you are not sure of your cleaner's chloride content, contact your cleaner supplier. If they tell you that your present cleaner contains chlorides, ask if they have an alternative. Avoid cleaners containing quaternary salts, as they can attack stainless steel, causing pitting and rusting.
- **Rinse –** When using chlorinated cleaners, you must rinse and wipe dry immediately. It is better to wipe standing cleaning agents and water as soon as possible. Allow the stainless steel equipment to air dry. Oxygen helps maintain the passivity film on stainless steel.
- **Never Use Hydrochloric Acid (Muriatic Acid) on Stainless Steel –** Even diluted, hydrochloric acid can cause corrosion, pitting and stress corrosion cracking of stainless steel.
- **Water Treatment –** To reduce deposits, soften hard water when possible. Installation of certain filters can remove corrosive and distasteful elements. Salts in a properly maintained water softener can also be to your advantage. Contact a treatment specialist if you are not sure of the proper water treatment.
- **Regularly Restore & Passivate Stainless Steel –** Stainless steel gets its stainless properties from the protective chromium oxides on its surface. If these oxides are removed by scouring, or by reaction with harmful chemicals, then the iron in the steel is exposed and can begin to oxidize, or rust. Passivation is a chemical process that removes free iron and other contaminants from the surface of stainless steel, allowing the protective chromium oxides to re-form.

DESCALING & SANITIZING

You should fully descale your ice machine every 6 months. Descaling also involves removing key ice machine parts and rinsing them and the inside of the machine with ice machine descaler.

Sanitizing the ice machine removes potential biological contaminations and molding. The sanitation process is identical to the descaling process, except that a sanitizing agent is used in place of the descaling chemicals.



WARNING! WEAR RUBBER GLOVES AND EYE PROTECTION WHEN HANDLING ICE MACHINE DESCALER OR SANITIZER.



CAUTION! DO NOT COMBINE DESCALER AND SANITIZER.
DESCALING PROCEDURE

1. Press and hold the clean button  for 3 seconds. The display will show **dES**.

2. Press the light  and / or the clean button until the display shows **dES** (descale only) or **bth** (both descale and sanitize), or **non** (none)



Run descale cycle only

Run both descale and sanitize cycles

Exit descale and sanitize menu

3. With the display showing the desired cycle, press the okay button . The display will show **Str**.



4. Press the light and / or the clean button until the display shows either **Str** or **Stb** (standby). This determines the ice machine's action upon completion of the selected cleaning cycle.

5. With the display showing the desired action, press the okay button. The selected cleaning cycle will begin.



Machine will begin ice making sequence



Machine will enter standby

6. The display will alternate between **PrE** and **CLn** (preclean) for approximately 3 minutes.

7. When the display shows **Add**, pour 6 fl. oz. of undiluted True Ice™ Machine Descaler into the spray compartment behind the water shutters.



Preclean stage

8. After adding the descaler, press the okay button. The automatic cycle will continue.

9. Wait for the rinse and drain cycles to complete



Add cleaning chemicals

(30 minutes). For light descaling, proceed to step 14.



While running the automatic clean cycle

10. Remove the ice guide, water shutters, spray bar and pump clean-out cap. See "Interior Components" (page [68](#)).



11. Mix a descaling solution of 10 fl. oz. undiluted True Ice™ Machine Descaler and 1 gal. of water.

12. With approximately half the descaling solution, clean the removed parts with a brush; then soak them for 20 minutes.

13. With the remaining solution, descale the ice bin, door, door gasket, spray compartment, and evaporator.

14. Rinse all parts with clean water.

SANITIZING PROCEDURE

1. Remove the ice guide, water supply, spray bar and pump clean-out cap. See "Interior Components" (page 68).
2. Mix 1.5 fluid ounces (3 tbsp) of 5.25% hypochlorite solution (chlorine bleach) with 3 gallons of warm water.
3. Use 1/2 of the solution to sanitize the removed parts. Soak the parts in the solution. **DO NOT RINSE THE PARTS AFTER SANITIZING.**
4. With the remaining solution, sanitize the interior surfaces of the machine and the bin. **DO NOT RINSE THE SANITIZED AREAS.**
5. Reinstall the components.
6. Press and hold the clean button  for 3 seconds. The display will show **dES**.
7. Press the light  and / or the clean button until the display shows **SAn** (descal only) or **bth** (both descale and sanitize), or **non** (none)



Run Sanitize cycle only



Run both descale and sanitize cycles



Exit descale and sanitize menu

8. With the display showing the desired cycle, press the okay button . The display will show **Str**.



9. Press the **LIGHT** and / or the **CLEAN** button until the display shows either **Str** (startup) or **Stb** (standby). This determines the ice machine's action upon completion of the selected cleaning cycle.



Machine will begin ice making sequence



Machine will enter standby

10. With the display showing the desired action, press the okay button. The selected cleaning cycle will begin.
11. The display will alternate between **PrE** and **CLn** (preclean) for approximately 3 minutes.
12. When the display shows **Add**, pour 2 teaspoons of 5.25% hypochlorite solution (chlorine bleach) into the spray compartment behind the water shutters.



Preclean stage

13. After adding the sanitizer solution, press the okay button. The automatic cycle will continue.



Add cleaning chemicals

14. Wait for the sanitizing cycle to finish. Immediately rinse off and dry any exterior areas where sanitizing solution may have spilled.



While running the automatic clean cycle

INTERIOR COMPONENTS

See the following for the removal and correct installation of the interior components.

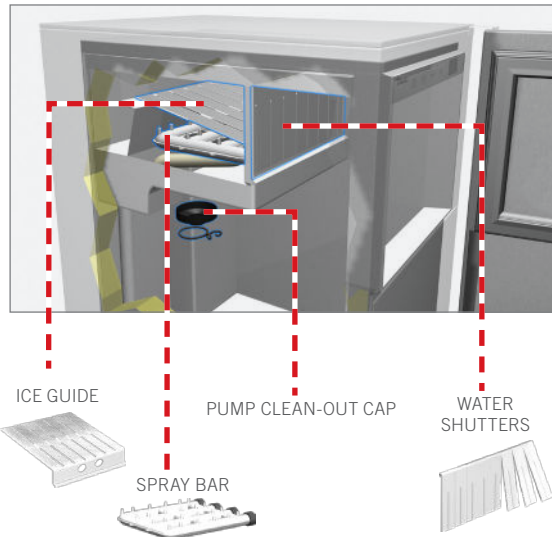
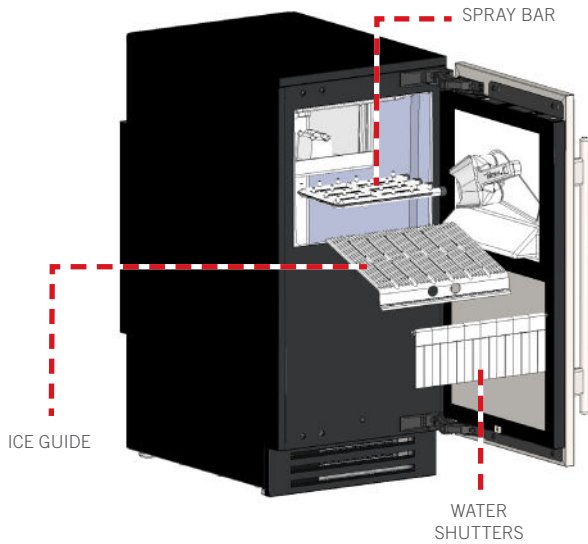

WATER SHUTTER

The water shutter hangs in front of the spray bar and ice guide. It prevents spraying water from escaping the evaporator compartment.

REMOVAL

Lift the shutter rod's ends from the recesses in the sidewall.

INSTALLATION PROCEDURE

Insert the shutter rod's ends into the recesses in the sidewall. To be correctly installed, the water shutter must–

- Hang from a shutter rod fully seated in the recessed end supports.
- Conceal the ice guide finger holes.



CORRECT. Ice guide finger holes are hidden; ice guide slotted holes are visible.

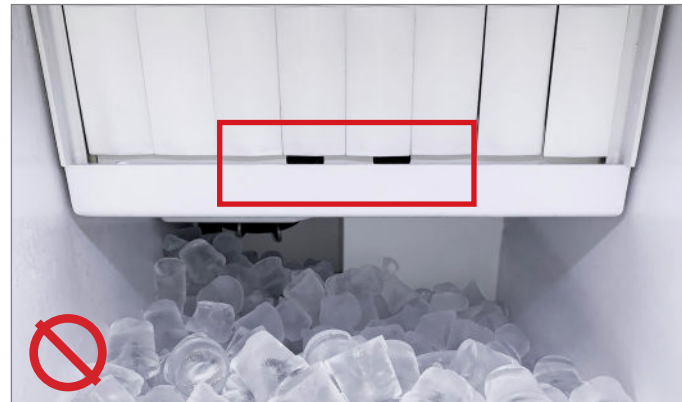

INCORRECT. Ice guide finger holes are visible.

ICE GUIDE

The ice guide sits over the spray nozzles and directs falling ice into the bin.

REMOVAL

Lift the front of the guide and pull the guide forward.

INSTALLATION PROCEDURE

Position the ice guide over the spray bar. To be correctly installed, the ice guide must–

- Be firmly positioned over the spray bar.
- Sit with its front edge inside the water trough.
- Have its slots aligned with the spray nozzles.



CORRECT. Ice guide positioned in the guide channel and flush against the back side of the water trough opening.



INCORRECT. Ice guide positioned too far inside the water trough.



INCORRECT. Ice guide positioned outside the water trough.

SPRAY BAR

REMOVAL

Carefully pull the spray bar from the water supply hose.

INSTALLATION PROCEDURE

The spray bar, located in the water trough, supplies water to the individual ice cube cups. To be correctly installed, the spray bar must–

- Be positioned with the clean-out caps on the right.
- Sit fully seated and horizontally level.

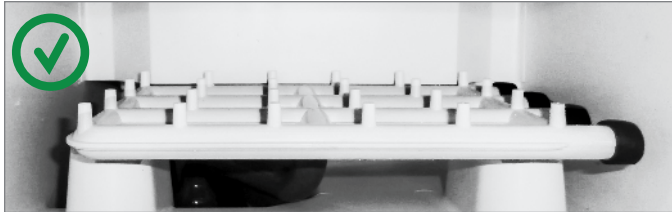

CORRECT. Spray bar is fully seated, level, and positioned with the clean-out caps on the right..

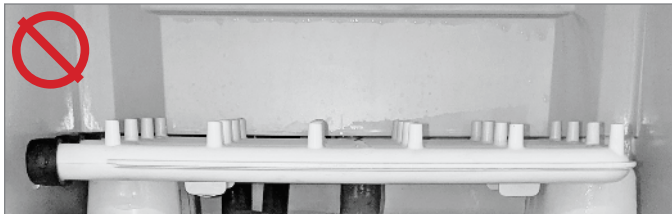

INCORRECT. Spray bar positioned with clean-out caps on the left.



INCORRECT. Spray bar is not fully seated or level.

PUMP CLEAN-OUT CAP

REMOVAL

1. Remove the pump clamp. See fig. 1.
2. Pull the clean-out cap down.

INSTALLATION PROCEDURE

1. Slide the clean-out cap over the hole beneath the pump.
2. Reinstall the pump cap clamp.

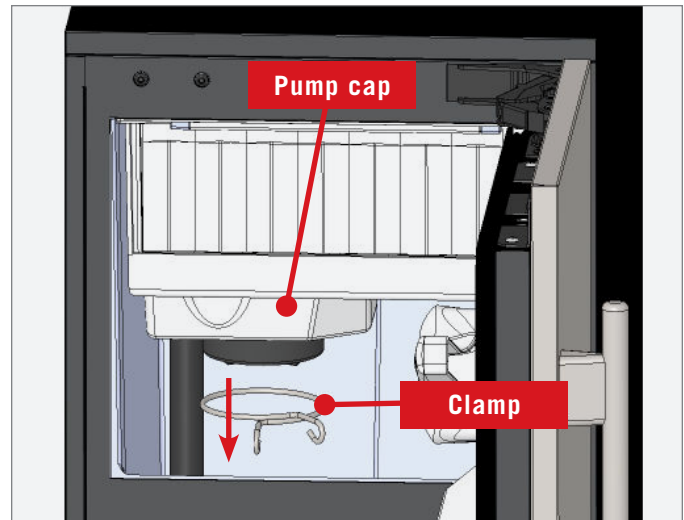



FIG. 1. Pump cap and clamp locations.

WINTERIZING

CAUTION: DO NOT ALLOW THE ICE MACHINE TO BE EXPOSED TO TEMPERATURES BELOW 32°F (0°C) WITHOUT WINTERIZING THE UNIT AS THIS WILL CAUSE ANY WATER IN THE MACHINE TO FREEZE. FAILURES CAUSED BY EXPOSURE TO FREEZING TEMPERATURES ARE NOT COVERED BY THE WARRANTY.

Use the following instructions to prepare your ice machine for storage or winterization:

PROCEDURE

1. Descale and sanitize the ice machine. See "Descaling & Sanitizing" (page [66](#)).
2. Turn off the water supply to the machine.
3. Disconnect the incoming water line from the back of the unit.
4. Remove and discard the water filter. See "Water Filter Replacement" step 1 (page [61](#)).
5. Press the power button  until the display shows **FiL**. Leave the machine on for 20 seconds, and then press power to turn the unit off.
6. Drain the evaporator compartment by removing the pump clean-out cap. See "Pump Clean-out Cap" (page [70](#)).
7. Pour 1 gallon of propylene glycol (RV antifreeze) into the bin drain to fill the drain pump.
8. Once the drain pump shuts off and all the propylene glycol is drained, unplug the unit or turn off the circuit breaker.
9. Wipe down the interior bin with a dry clean cloth.
10. Re-install the pump clean-out cap.

RESTARTING

Use the following instructions to restart your ice machine after winterization:

PROCEDURE

1. Install a new water filter in the unit. See "Water Filter Installation" (page [38](#)).
2. Reconnect the incoming water line and turn on the water supply.
3. Plug in the unit.
4. Descale the ice machine. See "Descaling" (page [66](#)).
5. Press the power button  to start ice making.

NOTE: THE FRESH WATER THAT IS INTRODUCED DURING DESCALING AND START-UP WILL FLUSH THE PROPYLENE GLYCOL DOWN THE DRAIN.

SERVICING, REPLACING COMPONENTS & ADJUSTMENTS

REVERSING DOOR

DOOR ADJUSTMENT

CONTACT US



LUXURY REFRIGERATION WITH COMMERCIAL DNA

SERVICING & REPLACING COMPONENTS

NOTE: ANY CABINET ADJUSTMENTS ARE TO BE MADE AFTER THE CABINET HAS BEEN VERIFIED LEVEL AND PROPERLY SUPPORTED.

- Replace component parts with original equipment manufacturer (OEM) components.
- Contact the dealer or our parts department at **844-849-6179** or **TrueResidentialParts@truemfg.com** for replacement parts.
- Have a licensed service provider service your unit to minimize the risk of possible ignition due to incorrect parts or improper service and to ensure the operator's health and safety.
- Unplug the ice machine before cleaning or making any repairs. Powering off an electronic control may not remove power from all components (e.g., light circuits, perimeter heaters, and evaporator fans).

REVERSING DOOR

The new TUIADA-15 models come with articulating, soft-close hinges. The hinges can be installed on either the left-hand or right-hand orientation.

To order additional spacers of NSF cover screw caps, contact our parts department at **844-89-6226** or **TrueResidentialParts@TrueMfg.com**.

REQUIRED TOOLS

Required tools include (but may not be limited to) the following:

- 1/8" Hex Head Allen Wrench
- Putty Knife (if NSF cover present)

PROCEDURE

NOTE: Figures show converting a right-hinged door to a left-hinged door.

1. Loosen the hinge bolts and remove the door. See fig. 1.
 2. If NSF Cover is present, carefully pry screw caps from the cover to access the door bracket screws. See fig. 2.
 3. If present, remove the door skin. See fig. 3.
 4. Remove the existing spacer. See fig. 3.
 5. Remove the hinge assemblies from the door assembly. See fig. 4.
 6. Shift the door brackets to the opposite side. See fig. 5.
 7. Install the bottom hinge at the top and the top hinge on the bottom. See figs. 6 and 7.
 8. Install the door skin. If present, reinstall the NSF cover screw caps.
 9. Move the remaining door hardware to the opposite sides. See fig. 8.
 10. Install the reversed door. Be sure to fully tighten the hinge screws.
- NOTE: BE SURE TO INSTALL THE CORRECT SPACER FOR YOUR DOOR ORIENTATION.**
11. Verify the door closes correctly and the gasket seals without gaps. Adjust the door as needed. See "Door Adjustment" (page **77**).

SERVICING, REPLACING COMPONENTS & ADJUSTMENTS

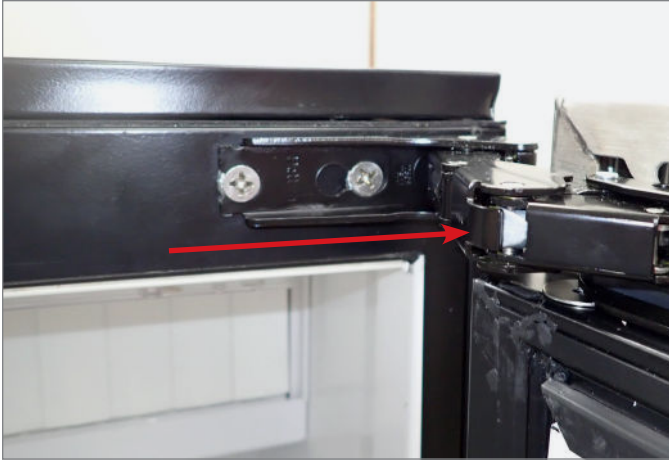

FIG. 1. Slide the door off the hinge bolts through the keyhole slots.

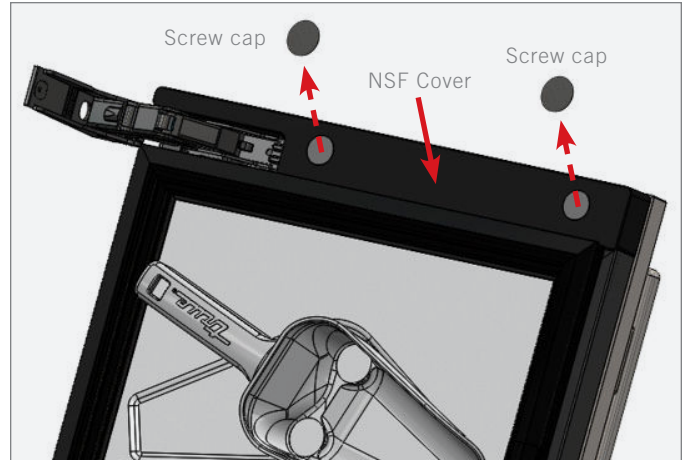

FIG. 2. Remove the NSF cover screw caps.

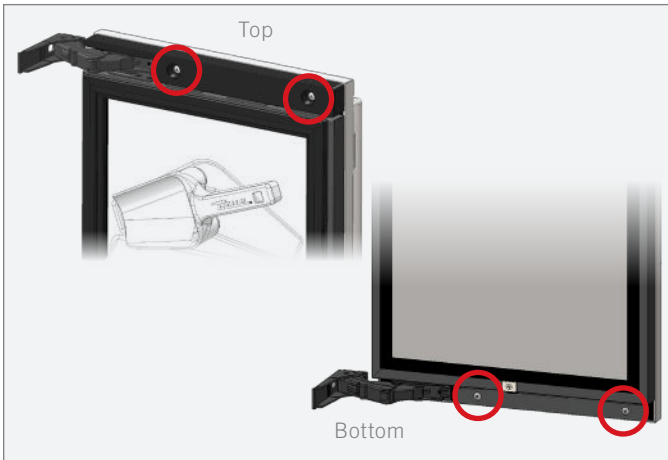

FIG. 3. Spacer and door bracket screw locations.

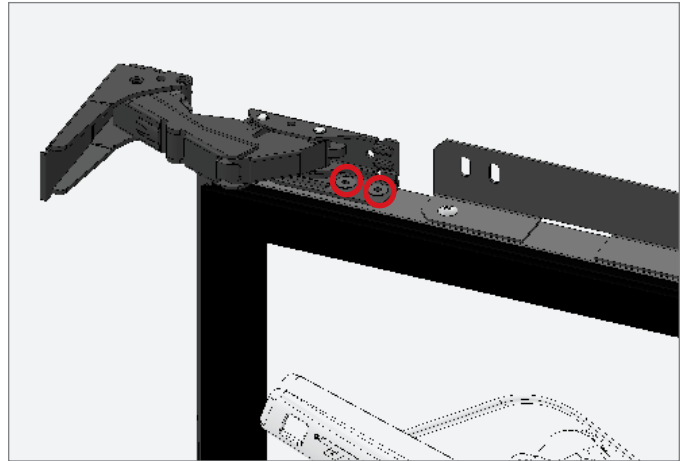

FIG. 4. Hinge door screw locations. Top hinge shown.

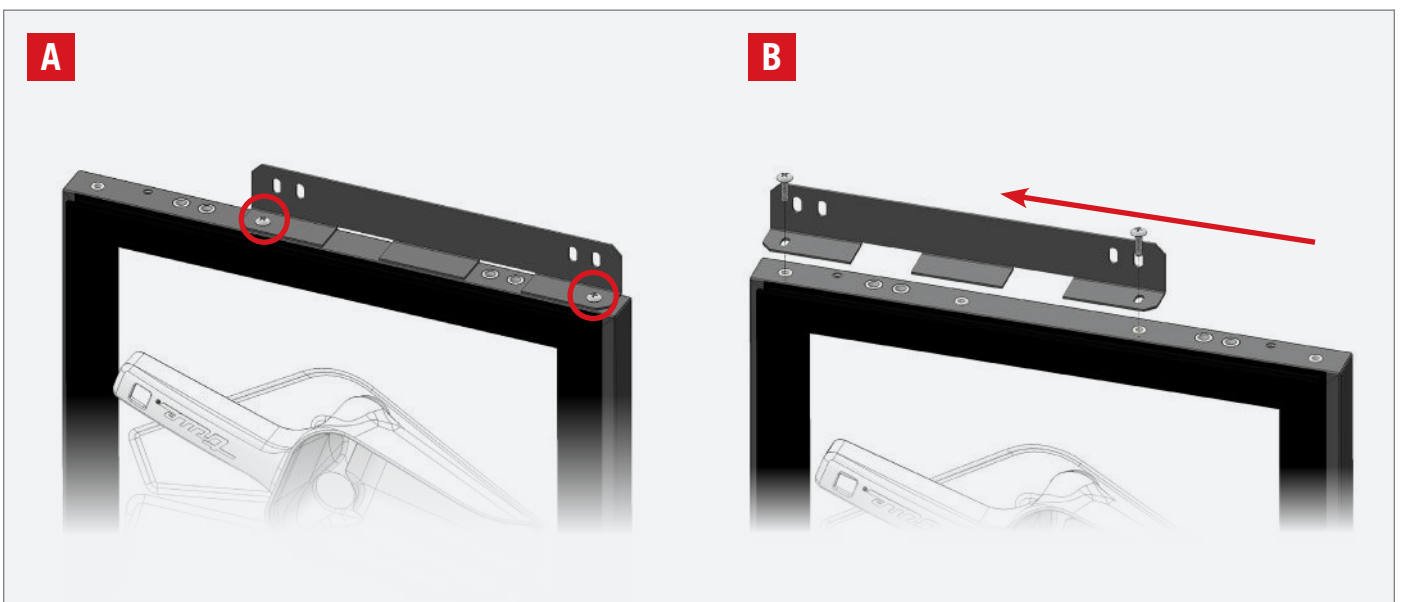

FIG. 5. Top Bracket shown.

A: Door Skin bracket screw locations.

B: Move the door skin bracket to the opposite side.

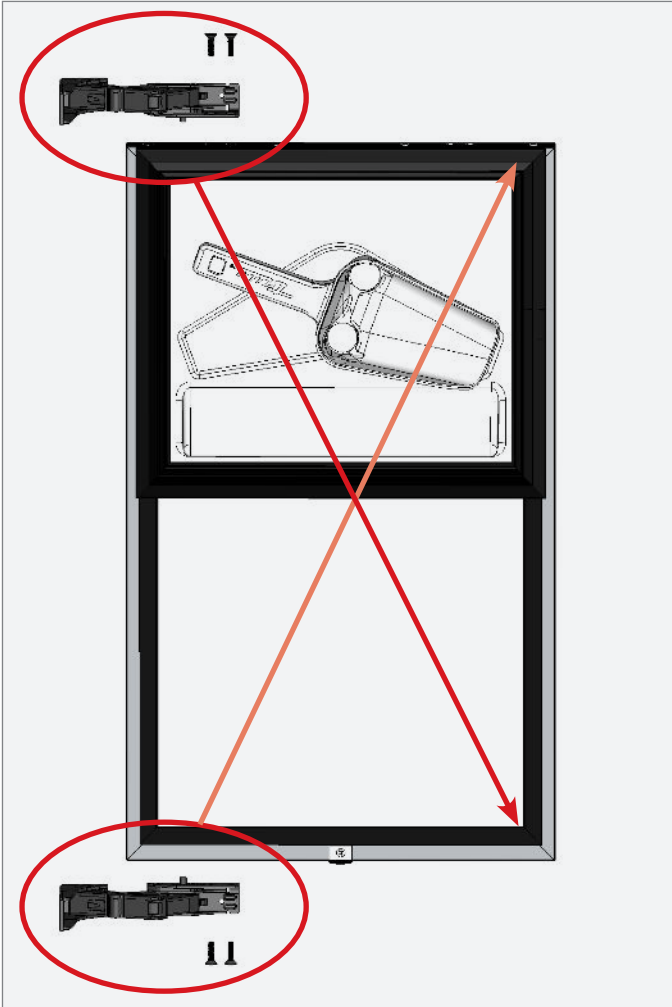

FIG. 6. Switch the top and bottom hinge assemblies with each other.

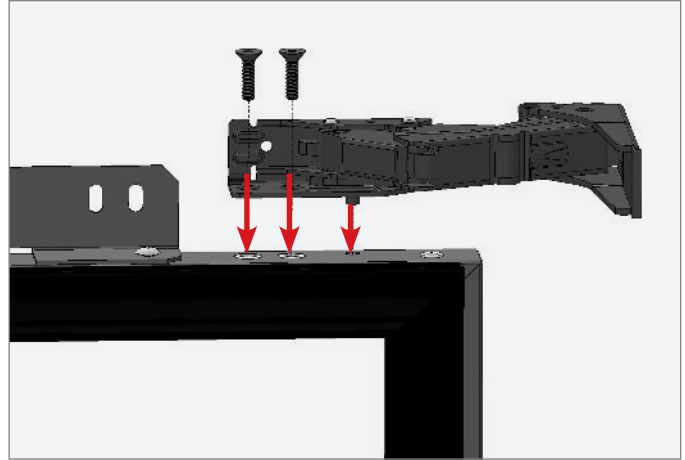

FIG. 7. Install the hinge assembly.

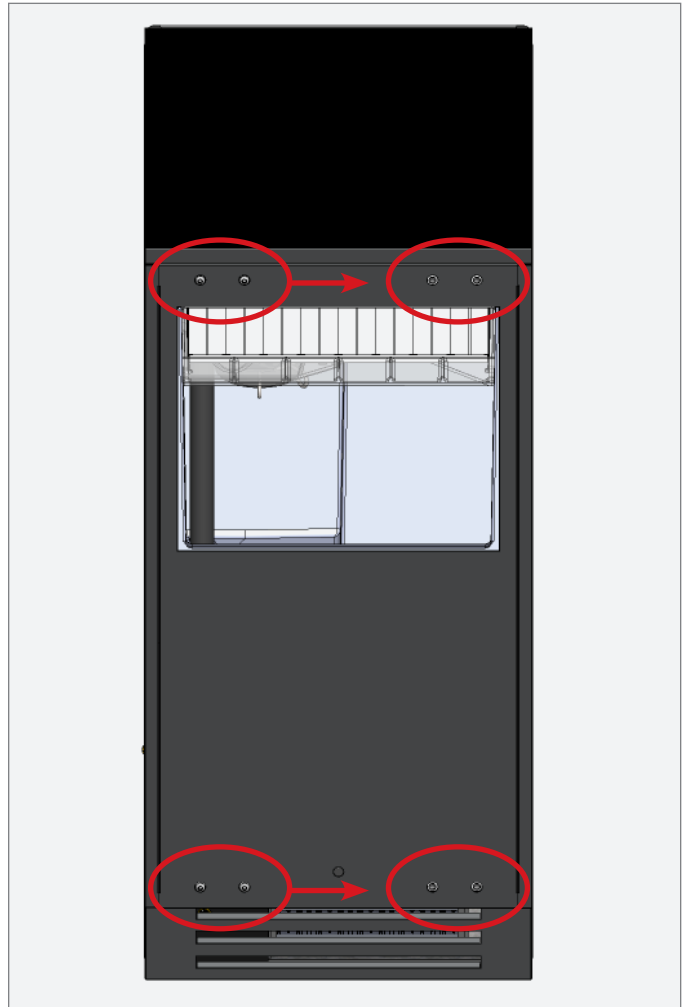

FIG. 8. Move the remaining door hardware to the opposite side.

DOOR ADJUSTMENT

Door skin bracket screw holes are slotted to assist with door adjustment. See figs. 1–3

PROCEDURE

1. If applicable, remove the NSF cover screw caps.
2. Loosen the door skin bracket and spacer screws. See figs. 1–3
3. Adjust the door skin / panel as needed.
4. Tighten the door skin bracket and spacer screws.
5. If applicable, reinstall NSF cover screw caps.

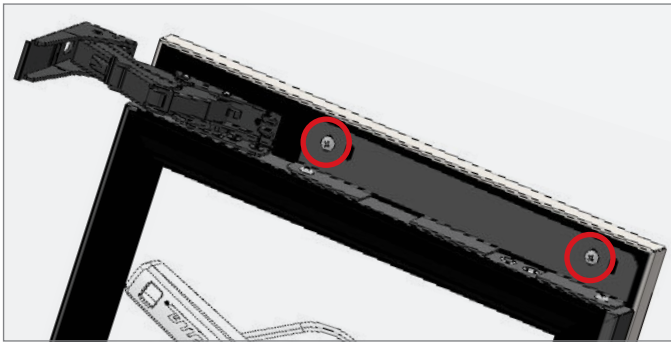

FIG. 1. Spacer / top door bracket screw locations.



FIG. 2. Bottom door bracket screw locations.

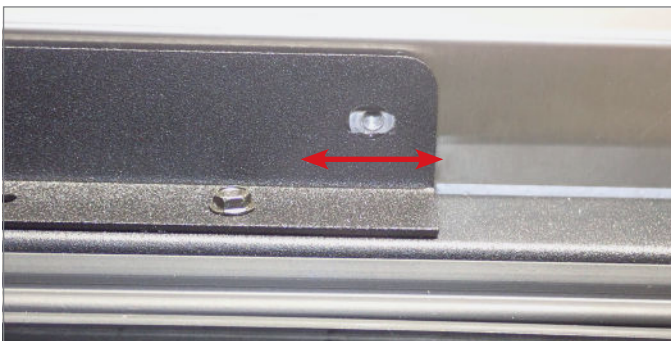

FIG. 3. Bracket screw holes are slotted for easy adjustment. Screw removed for illustration.

HANDLE TIGHTENING

Tighten the handle with a 3/32" Allen wrench.

CONTACT US

For any questions about installation, please contact your TRUE dealer or TRUE Residential Technical Service. Please have your model and serial number (see serial label location below) available so we can better assist you with your service- or parts-related inquires.

Customer Service

Phone: 888-616-8783
info@true-residential.com

Warranty Department

Phone: 844-849-6179
TrueResidentialWarranty@truemfg.com

Service Department

Phone: 844-746-9423
TrueResidentialService@truemfg.com

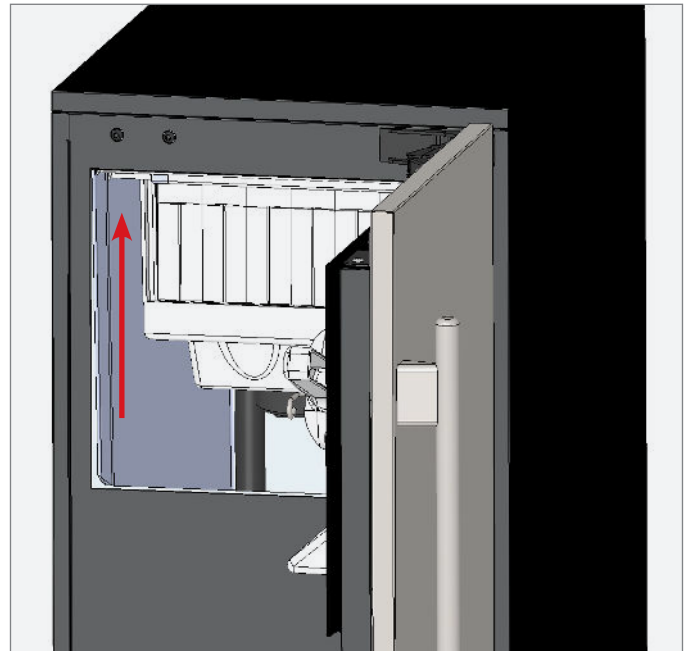

ADA-COMPLIANT WARRANTY STATEMENT

TO VIEW AND DOWNLOAD THE WARRANTY INFORMATION
FOR USA & CANADA, PLEASE SCAN THE QR CODE BELOW.



CONTACT US

true-caliber.com

636.240.2400 | toll free 888.616.8783



LUXURY REFRIGERATION WITH COMMERCIAL DNA

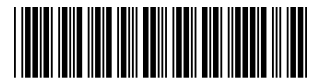

829074-E

BP_273016_05.26